

JVC

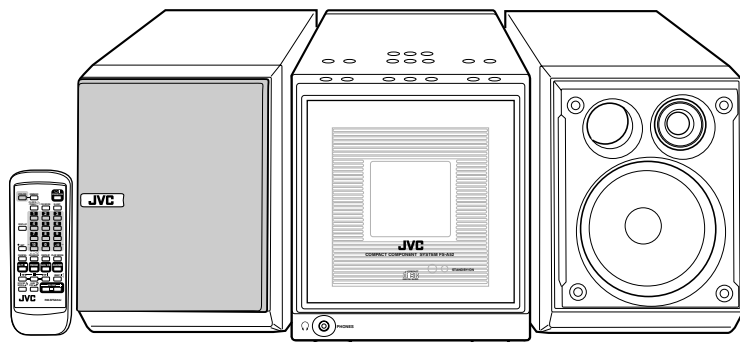

COMPACT COMPONENT SYSTEM

FS-A52 — Consists of CA-FSA52 and SP-UXA52



COMPACT
disc
DIGITAL AUDIO

INSTRUCTIONS

For Customer Use:

Enter below the Model No. and Serial No. which are located either on the rear, bottom or side of the cabinet. Retain this information for future reference.

Model No. _____

Serial No. _____

GVT0071-001B

[J]

Warnings, Cautions and Others

Mises en garde, précautions et indications diverses

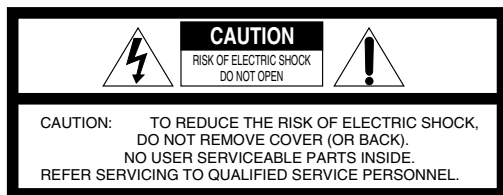

The lightning flash with arrowhead symbol, within an equilateral triangle is intended to alert the user to the presence of uninsulated "dangerous voltage" within the product's enclosure that may be of sufficient magnitude to constitute a risk of electric shock to persons.



The exclamation point within an equilateral triangle is intended to alert the user to the presence of important operating and maintenance (servicing) instructions in the literature accompanying the appliance.

WARNING: TO REDUCE THE RISK OF FIRE OR ELECTRIC SHOCK, DO NOT EXPOSE THIS APPLIANCE TO RAIN OR MOISTURE.

CAUTION

To reduce the risk of electrical shocks, fire, etc.:

1. Do not remove screws, covers or cabinet.
2. Do not expose this appliance to rain or moisture.

ATTENTION

Afin d'éviter tout risque d'électrocution, d'incendie, etc.:

1. Ne pas enlever les vis ni les panneaux et ne pas ouvrir le coffret de l'appareil.
2. Ne pas exposer l'appareil à la pluie ni à l'humidité.

Caution — STANDBY/ON button!

Disconnect the mains plug to shut the power off completely (the STANDBY/ON lamp goes off). The  STANDBY/ON button in any position does not disconnect the mains line.

- When the unit is on standby, the STANDBY/ON lamp lights red.
- When the unit is turned on, the STANDBY/ON lamp lights green.

The power can be remote controlled.

Attention — Commutateur STANDBY/ON!

Déconnectez la prise d'alimentation secteur pour mettre l'appareil complètement hors tension (le témoin STANDBY/ON s'éteint).

L'interrupteur  STANDBY/ON, sur n'importe quelle position, ne peut pas déconnecter l'appareil du secteur.

- Quand l'appareil est en mode de veille, le témoin STANDBY/ON est allumé en rouge.
- Quand l'appareil est sous tension, le témoin STANDBY/ON est allumé en vert.

L'alimentation peut être télécommandée.

1. CLASS 1 LASER PRODUCT
2. **DANGER:** Invisible laser radiation when open and interlock failed or defeated. Avoid direct exposure to beam.
3. **CAUTION:** Do not open the top cover. There are no user serviceable parts inside the Unit; leave all servicing to qualified service personnel.

1. PRODUIT LASER CLASSE 1
2. **ATTENTION:** Radiation laser invisible quand l'appareil est ouvert ou que le verrouillage est en panne ou désactivé. Éviter une exposition directe au rayon.
3. **ATTENTION:** Ne pas ouvrir le couvercle du dessus. Il n'y a aucune pièce utilisable à l'intérieur. Laisser à un personnel qualifié le soin de réparer votre appareil.

For U.S.A.

This equipment has been tested and found to comply with the limits for a Class B digital device, pursuant to part 15 of the FCC Rules. These limits are designed to provide reasonable protection against harmful interference in a residential installation.

This equipment generates, uses and can radiate radio frequency energy and, if not installed and used in accordance with the instructions, may cause harmful interference to radio communications. However, there is no guarantee that interference will not occur in a particular installation. If this equipment does cause harmful interference to radio or television reception, which can be determined by turning the equipment off and on, the user is encouraged to try to correct the interference by one or more of the following measures:

Reorient or relocate the receiving antenna.
Increase the separation between the equipment and receiver.
Connect the equipment into an outlet on a circuit different from that to which the receiver is connected.
Consult the dealer or an experienced radio/TV technician for help.

For Canada/pour le Canada

CAUTION: TO PREVENT ELECTRIC SHOCK, MATCH WIDE BLADE OF PLUG TO WIDE SLOT, FULLY INSERT.

ATTENTION: POUR EVITER LES CHOCS ELECTRIQUES, INTRODUIRE LA LAME LA PLUS LARGE DE LA FICHE DANS LA BORNE CORRESPONDANTE DE LA PRISE ET POUSSER JUSQU'AU FOND.

For Canada/pour le Canada

THIS DIGITAL APPARATUS DOES NOT EXCEED THE CLASS B LIMITS FOR RADIO NOISE EMISSIONS FROM DIGITAL APPARATUS AS SET OUT IN THE INTERFERENCE-CAUSING EQUIPMENT STANDARD ENTITLED "DIGITAL APPARATUS", ICES-003 OF THE DEPARTMENT OF COMMUNICATIONS.

CET APPAREIL NUMERIQUE RESPECTE LES LIMITES DE BRUITS RADIOELECTRIQUES APPLICABLES AUX APPAREILS NUMERIQUES DE CLASSE B PRESCRITES DANS LA NORME SUR LE MATERIEL BROUILLEUR: "APPAREILS NUMERIQUES", NMB-003 EDICTEE PAR LE MINISTRE DES COMMUNICATIONS.



Introduction

We would like to thank you for purchasing one of our JVC products. Before operating this unit, read this manual carefully and thoroughly to obtain the best possible performance from your unit, and retain this manual for future reference.

About This Manual

This manual is organized as follows:

- This manual mainly explains playback using the remote control, and the other operations such as recording operations using the buttons on the unit. You can use the buttons both on the remote control and on the unit for the same operations if they have the same or similar names (or marks), unless mentioned otherwise.
- Basic and common information that is the same for many functions is grouped in one place, and is not repeated in each procedure. For instance, we do not repeat the information about turning on/off the unit, setting the volume, changing the sound effects, and others, which are explained in the section “Basic and Common Operations” on pages 10 – 13.
- The following marks are used in this manual:

	Gives you warning and caution to prevent from damage or risk of fire/electric shock. Furthermore, gives you information which is not good for obtaining the best possible performance from the unit.
	Gives you information and hints you had better know.

Precautions

Installation

- Install in a place which is level, dry and neither too hot nor too cold—between 5°C (41°F) and 35°C (95°F).
- Install the unit in a location with adequate ventilation to prevent internal heat buildup in the unit.
- Leave sufficient distance between the unit and the TV.
- Keep the speakers away from the TV to avoid interference with TV.

 DO NOT install the unit in a location near heat sources, or in a place subject to direct sunlight, excessive dust or vibration.

Power sources

- When unplugging the unit from the wall outlet, always pull the plug, not the AC power cord.



DO NOT handle the AC power cord with wet hands.

Moisture condensation

Moisture may condense on the lens inside the unit in the following cases:

- After starting heating in the room
 - In a damp room
 - If the unit is brought directly from a cold to a warm place
- Should this occur, the unit may malfunction. In this case, leave the unit turned on for a few hours until the moisture evaporates, unplug the AC power cord, then plug it in again.

Others

- Should any metallic object or liquid fall into the unit, unplug the AC power cord and consult your dealer before operating any further.
- If you are not going to operate the unit for an extended period of time, unplug the AC power cord from the wall outlet.



DO NOT disassemble the unit since there are no user serviceable parts inside.

If anything goes wrong, unplug the AC power cord and consult your dealer.

Contents

Location of the Buttons	3	Playing Back a CD	17
Main Unit	3	Precautions on CD Playback	18
Remote Control	5	Playing Back the Entire CD—Normal Play	18
Getting Started	6	Basic CD Operations	19
Unpacking	6	Programing the Playing Order of the Tracks	
Putting the Batteries into the Remote Control	6	—Program Play	20
Connecting Antennas	7	Playing at Random—Random Play	21
Connecting Speakers	8	Repeating Tracks—Repeat Play	21
Connecting Other Equipment	9	Playing Back a Tape	22
Basic and Common Operations	10	Playing Back a Tape	23
Turning On the Power	11	Using External Equipment	24
Selecting the Sources and Starting Play	11	Listening to External Equipment	25
Adjusting the Volume	12	Recording from This Unit	
Turning On/Off the Key-touch Tone	12	to External Equipment	25
Reinforcing the Bass Sound	12	Recording on Tapes	26
Selecting the Sound Modes	12	Before You Start Recording	27
Setting the Display Illumination	13	Recording FM/AM Broadcasts	28
Listening to FM and AM Broadcasts	14	Recording CD—CD Synchronized Recording	28
Tuning in a Station	15	Recording External Equipment	29
Presetting Stations	15	Using the Timers	30
Tuning in a Preset Station	16	Setting the Clock	31
		Using Recording Timer	31
		Using Daily Timer	32
		Using Sleep Timer	34
		Timer Priority	34
		Maintenance	35
		Troubleshooting	36
		Specifications	36

Location of the Buttons

Become familiar with the buttons on your unit.

Main Unit

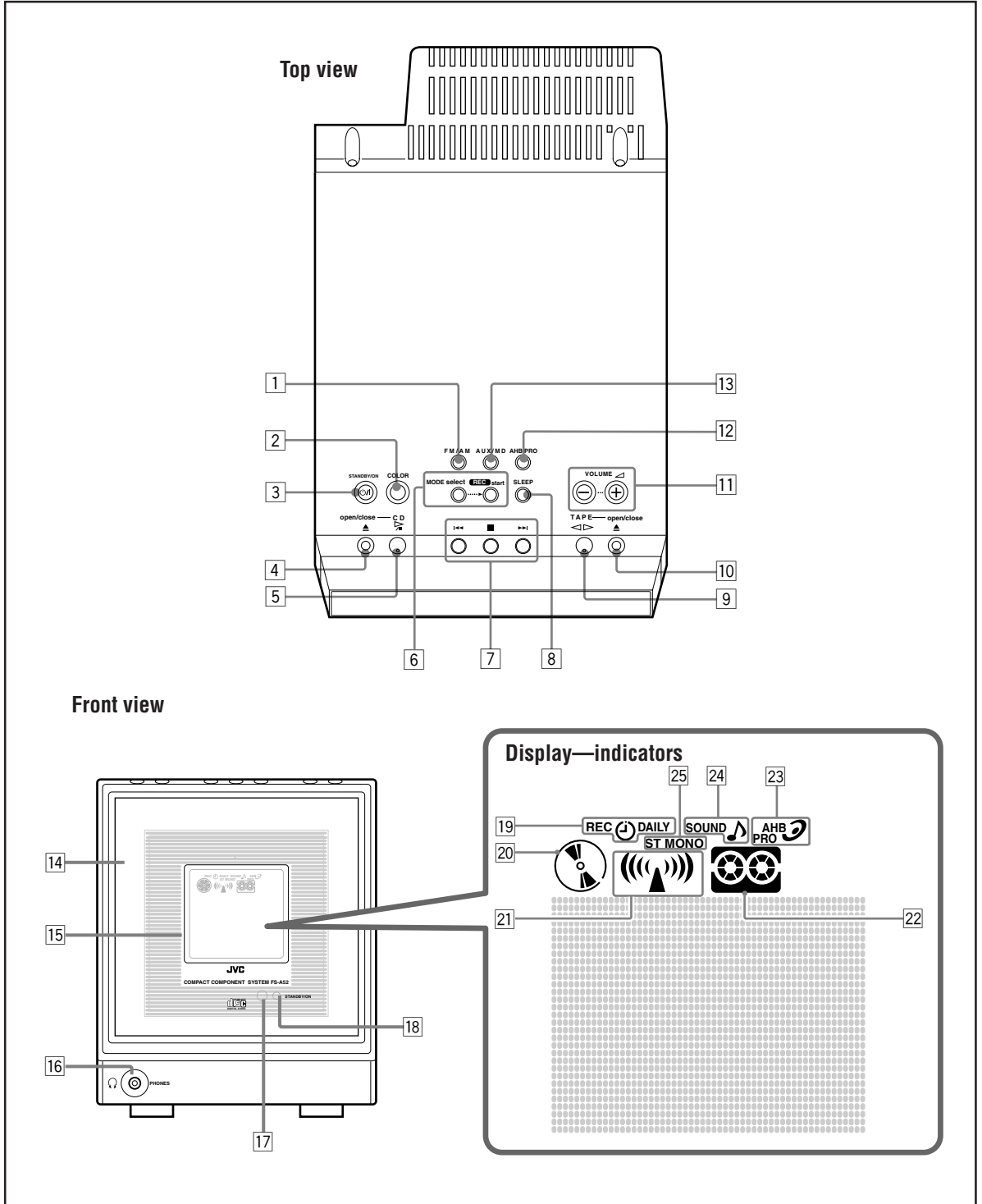

See pages in the parentheses for details.

Main unit

- 1 FM/AM button (11, 15)
 - Pressing this button also turns on the unit.
- 2 COLOR button (9, 13)
- 3 \odot /I STANDBY/ON button (11)
- 4 CD open/close \blacktriangle button (18 – 20)
 - Pressing this button also turns on the unit.
- 5 CD \triangleright / \parallel (play/pause) button (11, 18, 28)
 - Pressing this button also turns on the unit.
- 6 MODE select and REC start buttons (28, 29)
- 7 Multi operation buttons
 - \blacktriangleleft (reverse skip), \blacksquare (stop), and \blacktriangleright (forward skip)
- 8 SLEEP button (34)
- 9 TAPE \triangleleft \triangleright (play) button (11, 23, 28, 29)
 - Pressing this button also turns on the unit.
- 10 TAPE open/close \blacktriangle button (23)
 - Pressing this button also turns on the unit.
- 11 VOLUME + / – buttons (12, 25)
- 12 AHB (Active Hyper Bass) PRO button (12, 25)
- 13 AUX/MD button (11, 25, 29)
 - Pressing this button also turns on the unit.
- 14 Electronic swing panel
- 15 Display
 - Shows the source name and some indicators, etc.
- 16 PHONES (\odot) jack—stereo mini-type (12)
- 17 Remote sensor
- 18 STANDBY/ON lamp (11)

Display—indicators

- 19 Timer mode indicators (31 – 34)
 - \odot (Timer), DAILY (Daily Timer), and REC (Recording Timer)
- 20 CD indicator
 - Lights when CD is in the disc tray.
- 21 Tuner indicator
 - Lights when the tuner is selected as the source.
- 22 Tape indicator
 - Lights when a cassette is in the cassette loading slot.
- 23 AHB (Active Hyper Bass) PRO indicator (12)
- 24 SOUND indicator (12)
- 25 ST (stereo) and MONO indicators (15)

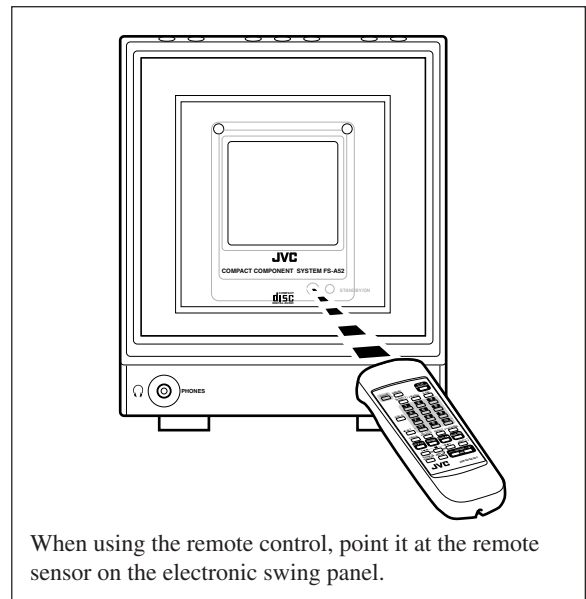

Remote Control

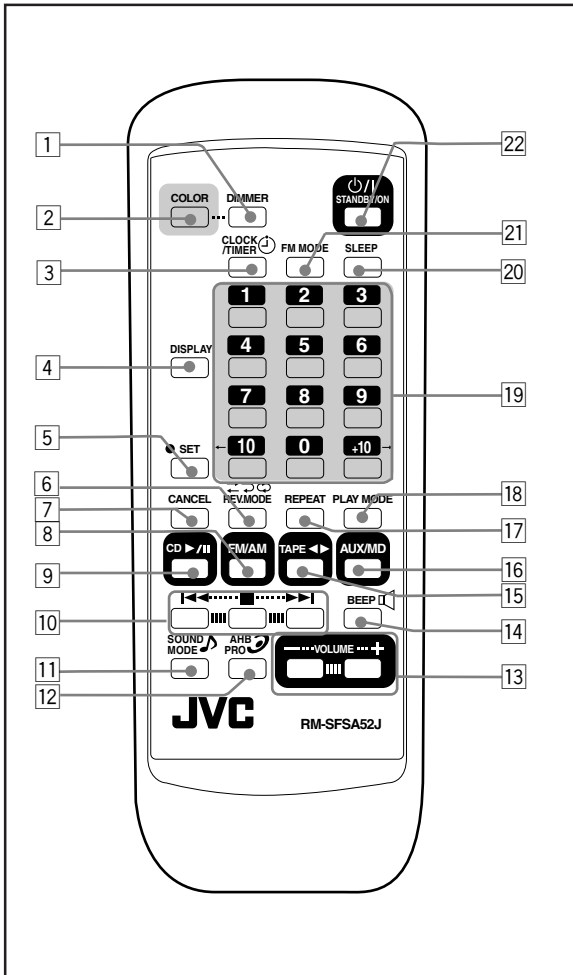

Remote control

- 1 DIMMER button (13, 31)
- 2 COLOR button (9, 13)
- 3 CLOCK/TIMER button (31 – 33)
- 4 DISPLAY button (16, 19, 23, 28, 29)
- 5 SET button (13, 15, 31 – 34)
- 6 REV. (reverse) MODE button (23)
- 7 CANCEL button (20, 31, 32)
- 8 FM/AM button (11, 15, 16)
 - Pressing this button also turns on the unit.
- 9 CD ► / ◼◼ (play/pause) button (11, 18 – 21)
 - Pressing this button also turns on the unit.
- 10 Multi operation buttons
 - ◀◀ (reverse skip), ◼ (stop), and ▶▶ (forward skip)
- 11 SOUND MODE button (12, 25)
- 12 AHB (Active Hyper Bass) PRO button (12, 25)
- 13 VOLUME + / - buttons (12, 25)
- 14 BEEP button (12)
- 15 TAPE ◀ ▶ button (11, 23)
 - Pressing this button also turns on the unit.
- 16 AUX/MD button (11, 25)
 - Pressing this button also turns on the unit.
- 17 REPEAT button (21)
- 18 PLAY MODE button (20, 21)
- 19 Number buttons
 - 0, 1 – 10, +10 buttons
 - ◀ / ▶ buttons (13)
- 20 SLEEP button (34)
- 21 FM MODE button (15)
- 22 ◻/◻ STANDBY/ON button (11, 32, 33)

Unpacking

Make sure that you have all the following items.
The number in parentheses indicates the quantity of the pieces supplied.

- FM antenna (1)
- AM loop antenna (1)
- AC power cord (1)
- Remote control (1)
- Batteries (2)

If anything is missing, consult your dealer immediately.

Putting the Batteries into the Remote Control

Insert the batteries—R6P(SUM-3)/AA(15F)—into the remote control, by matching the polarity (+ and –) on the batteries with the + and – marking on the battery compartment.

When the remote control can no longer operate the unit, replace both batteries at the same time.

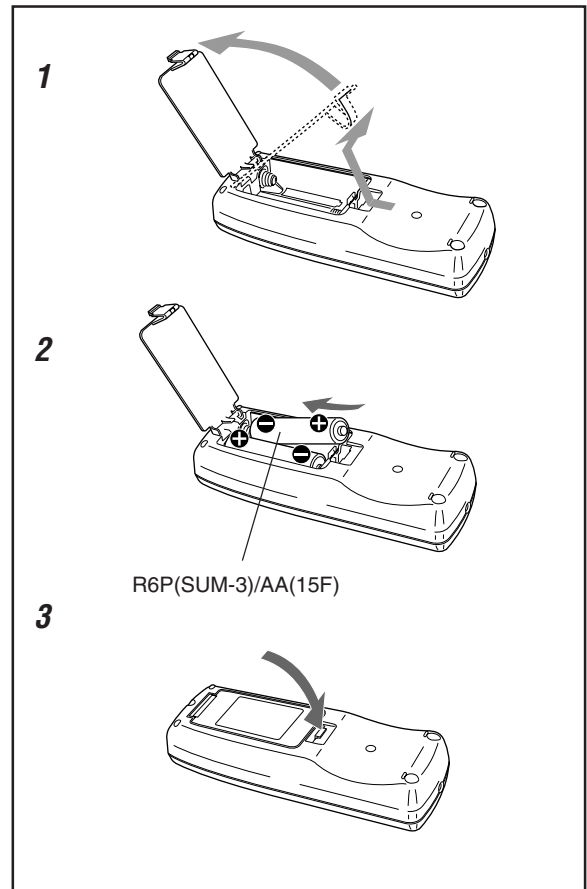

- DO NOT use an old battery together with a new one.
- DO NOT use different types of batteries together.
- DO NOT expose batteries to heat or flame.
- DO NOT leave the batteries in the battery compartment when you are not going to use the remote control for an extended period of time. Otherwise, it will be damaged from battery leakage.

Connecting Antennas

FM antenna

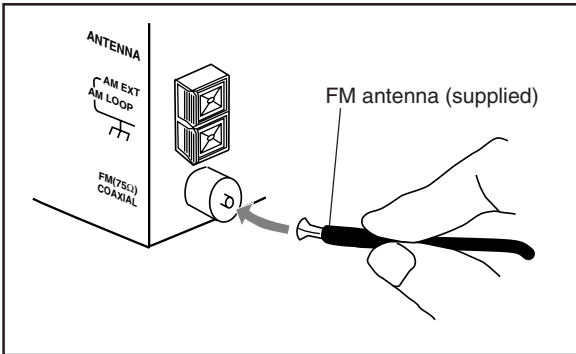

- 1** Attach the FM antenna to the FM (75 Ω) COAXIAL terminal.
- 2** Extend the FM antenna.
- 3** Fasten it up in the position which gives you the best reception.



About the supplied FM antenna

The FM antenna supplied with this unit can be used as temporary measure. If reception is poor, you can connect an outdoor FM antenna.

To connect an outdoor FM antenna

Before connecting it, disconnect the supplied FM antenna.

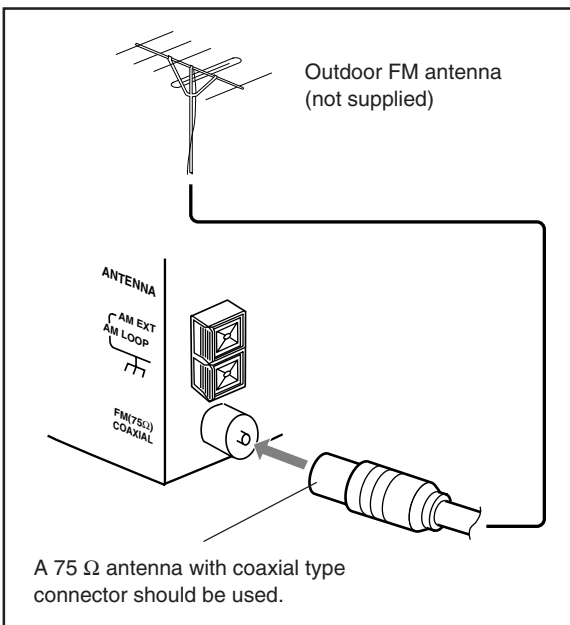

AM antenna

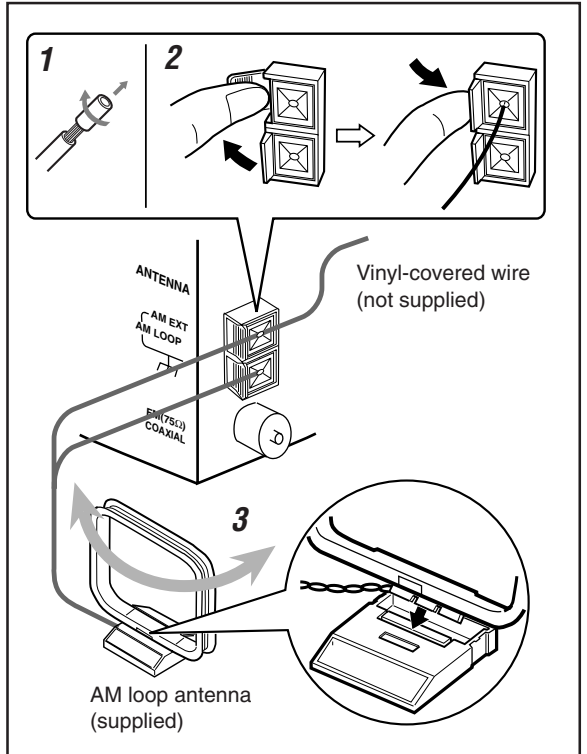

- 1** If cords are covered with insulation, twist the core of the cord at the end of each cord, then remove the insulation.
- 2** Connect the AM loop antenna to the AM LOOP terminals as illustrated.
- 3** Turn the AM loop antenna until you have the best reception.

To connect an outdoor AM antenna

When reception is poor, connect a single vinyl-covered wire to the AM EXT terminal and extend it horizontally. The AM loop antenna must remain connected.



For better reception of both FM and AM

- Make sure the antenna conductors do not touch any other terminals and connecting cords.
- Keep the antennas away from metallic parts of the unit, connecting cords, and the AC power cord.

Connecting Speakers

To connect speakers

You can connect the speakers by following the procedure below:

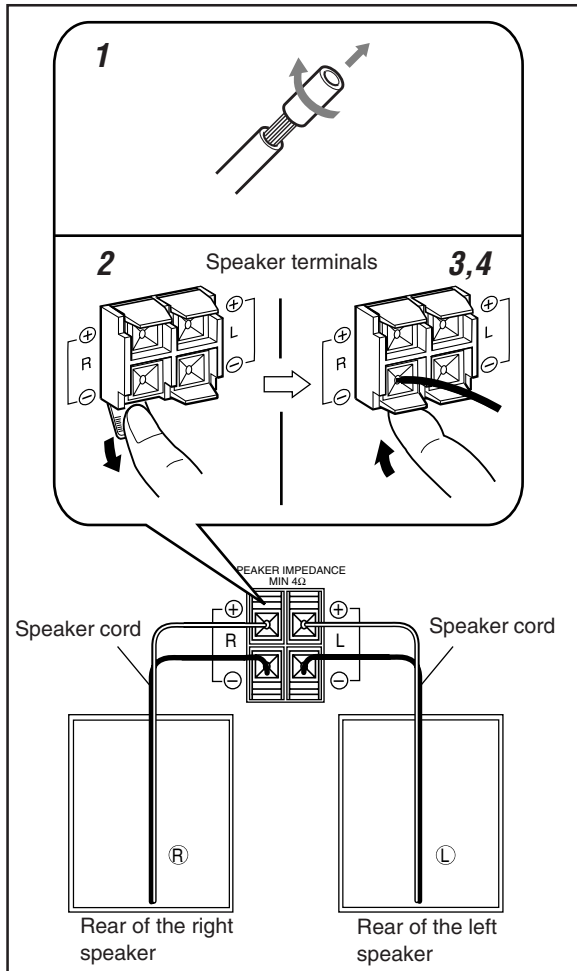

- 1** If cords are covered with insulation, twist the core of the cord at the end of each cord, then remove the insulation.
- 2** Open the speaker terminal.
- 3** Insert the end of the speaker cord to the terminal. Match the polarity: White cord to (+) terminal and black cord to (-) terminal.
- 4** Close the speaker terminal on the rear of the unit.

Use only speakers with the speaker impedance—4 Ω to 16 Ω.

To remove the speaker grilles

The speaker grilles are removable.

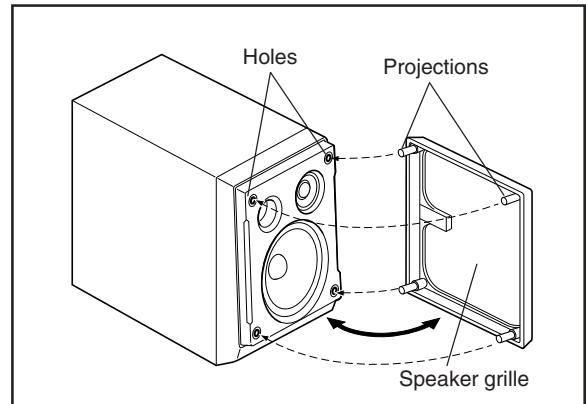

To remove the speaker grille, insert your fingers at the top of the speaker grille, then pull towards you. Do the same at the bottom.

To attach the speaker grille, put the projections of the speaker grille into the holes of the speaker.

Connecting Other Equipment

You can connect both of the analog and digital equipment. When you connect and use the equipment, refer also to its manual supplied.



- DO NOT connect other equipment while the power is on.
- DO NOT plug in any equipment until all connections are complete.

To connect analog audio equipment

Be sure that the plugs of the audio cords and the jacks on the rear of the unit are color-coded: White plugs and jacks are for left audio signals, and red ones for right audio signals.

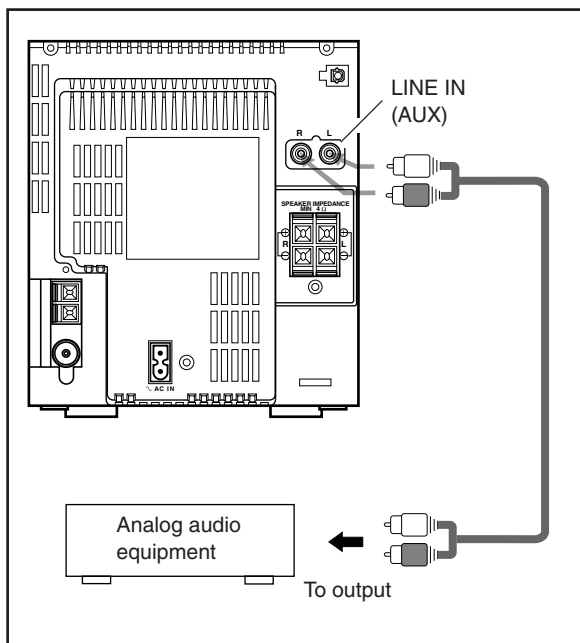

For playing the other equipment through this unit, connect between the audio output jacks on the other equipment and the LINE IN (AUX) jacks by using an audio cord (not supplied.)

To connect audio equipment with an optical digital input terminal

You can record CD sound onto the connected digital equipment. Connect an optical digital cord (not supplied) between the optical digital input terminal on the other equipment and the OPTICAL DIGITAL OUT terminal.

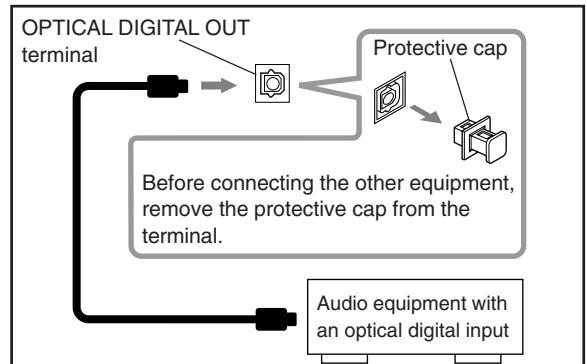

NOW, you can plug the AC power cord.

IMPORTANT: Be sure to check all connections to be done before plugging the AC power cord into a wall outlet.

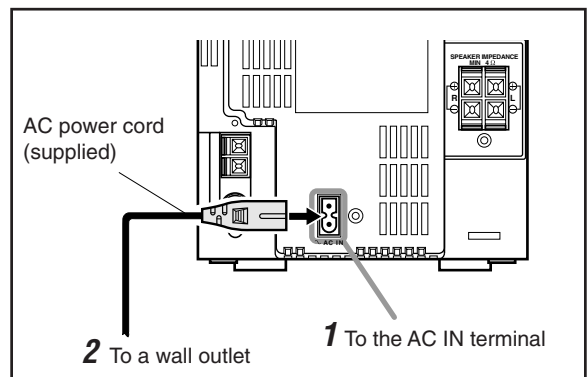

When connecting the AC power cord into a wall outlet, the unit automatically starts the display illumination.

To stop and cancel the display demonstration, press COLOR during display illumination—while the unit is turned off (on standby.)

To start the display illumination manually, press COLOR again while the unit is turned off (on standby.)

Basic and Common Operations

Continued

The buttons emphasized in the illustration below are used and explained in this section (pages 11 to 13.)

Remote control

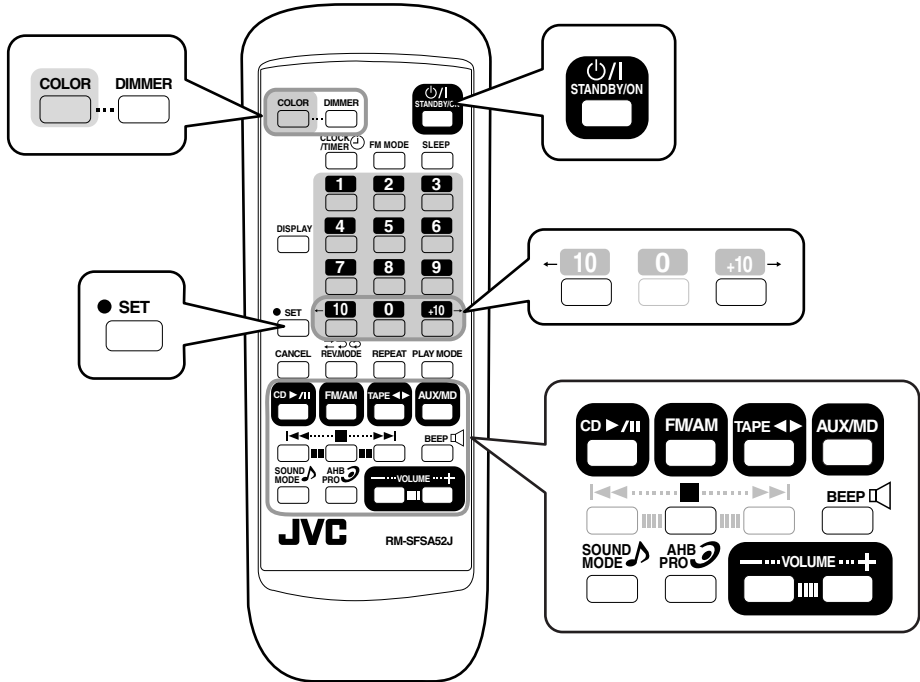

Main unit (Top view)

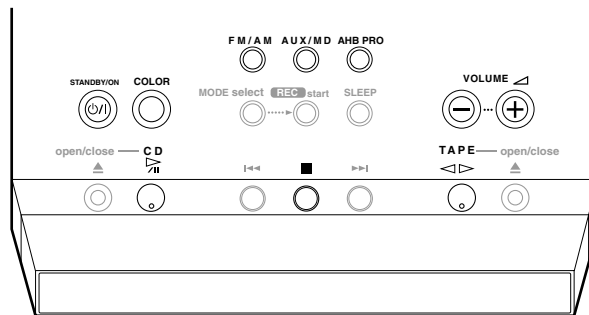

Main unit (Front view)

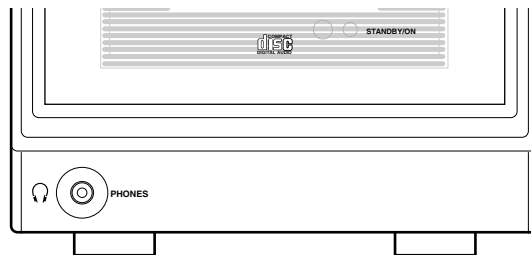

Turning On the Power

When you press the play buttons (CD ► / II, TAPE ◀ ►) for a particular source or FM/AM and AUX/MD, the unit automatically turns on (and starts playback if the source is ready.)

To turn on the unit without playing, press
⓪/ I STANDBY/ON.

The STANDBY/ON lamp on the electronic swing panel lights green.

To turn off the unit (on standby), press

⓪/ I STANDBY/ON again.

The STANDBY/ON lamp on the electronic swing panel lights red.

- “AM12:00” appears on the display until you set the built-in clock. After setting the clock, the clock time will appear on the display while the unit is turned off (on standby.)
- A little power is always consumed even while the unit is on standby.

To set the built-in clock, see page 31.

To switch off the power supply completely, unplug the AC power cord from the AC outlet.



When you unplug the AC power cord or if a power failure occurs

The clock setting, the tuner preset stations and other settings will be erased.

Selecting the Sources and Starting Play

To select the tuner, press FM/AM.

The unit automatically turns on (when the unit is on standby) and the last selected station is tuned in.

Each time you press FM/AM, the band alternates between FM and AM.

- For more detailed operations, see pages 14 to 16.

To select the CD player, press CD ► / II.

The unit automatically turns on (when the unit is on standby), and “CD” appears on the display. Play will start if a CD is on the disc tray. (“NO DISC” will appear on the display if a CD is not loaded.)

To stop playback, press ■.

- For more detailed operations, see pages 17 to 21.

To select the cassette deck, press TAPE ◀ ►.

The unit automatically turns on (when the unit is on standby), and “TAPE” appears on the display. Play will start if a cassette is in the cassette loading slot. (“NO TAPE” will appear on the display if a cassette is not in the cassette loading slot.)

To stop playback, press ■.

- For more detailed operations, see pages 22 and 23.

To select external equipment, press AUX/MD.

The unit automatically turns on (when the unit is on standby), and “AUX” appears on the display.

- For more detailed operations, see pages 24 and 25.
- For operating the external equipment, see the manuals supplied with them.

Adjusting the Volume

You can adjust the volume level while the unit is turned on. The volume level has no effect on recording.

To increase the volume, press VOLUME +.

To decrease the volume, press VOLUME –.

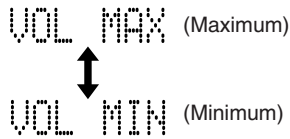

The volume level meter appears on the display.

- The volume level can be adjusted in 41 steps (VOL MIN, VOL 1 – VOL 39, and VOL MAX.)
- When pressing and holding the button, you can change the volume level continuously.



For private listening

Connect the headphones to the PHONES jack. No sound comes out of the speakers. Be sure to turn down the volume before connecting or putting on the headphones.



DO NOT turn off (on standby) the unit with the volume set to an extremely high level; otherwise, the sudden blast of sound can damage your hearing, speakers and/or headphones when you turn on the unit or start playing any source.

REMEMBER you cannot adjust the volume level while the unit is on standby mode.

Turning On/Off the Key-touch Tone

If you do not want the key-touch tone to beep each time you press buttons, you can deactivate it while the unit is turned on.

On the remote control ONLY:

Press BEEP.

- Each time you press the button, the key-touch tone turns on (BEEP ON) and off (BEEP OFF) alternately:

BEEP ON ↔ BEEP OFF

Reinforcing the Bass Sound

The richness and fullness of the bass sound is clearly maintained regardless of how low you set the volume—Active Hyper Bass PRO. You can select the bass effect levels while the unit is turned on. The AHB PRO can be applied only to playback sounds, and cannot be used for recording.

To get the effect, press AHB PRO.

The AHB PRO indicator lights on the display.

- Each time you press the button, the effect changes as follows:

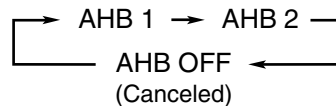

AHB 1: Bass sound is clearly heard even in the low volume.

AHB 2: Bass sound is more effective than AHB 1.

AHB OFF: Cancels the AHB PRO.

The AHB PRO indicator goes off from the display.

To check the AHB PRO setting currently selected, press AHB PRO once while the AHB PRO indicator is lit.

Selecting the Sound Modes

You can select one of the 4 preset sound modes while the unit is turned on. The sound modes can be applied only to playback sounds, and cannot be used for recording.

On the remote control ONLY:

To select the sound modes, press SOUND MODE repeatedly until the sound mode you want appears on the display.

The SOUND indicator also lights on the display.

- Each time you press the button, the sound mode changes as follows:

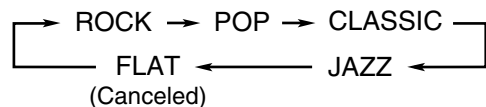

ROCK: Boosts low and high frequency. Good for acoustic music.

POP: Good for vocal music or voice.

CLASSIC: Good for classical music.

JAZZ: Good for jazz music.

FLAT: Cancels the sound mode.

The SOUND indicator goes off from the display.

To check the sound mode currently selected, press SOUND MODE once while the SOUND indicator is lit.

Setting the Display Illumination

You can change the color and brightness of the display illumination.

To select the color pattern

You can select the color pattern by your preference.

While the unit is turned on, press **COLOR** repeatedly until the color pattern you want appears on the display.

- Each time you press the button, the color pattern changes as follows:

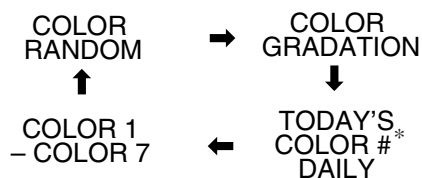

COLOR RANDOM: Changes the illumination color randomly every 2 seconds.

COLOR GRADATION: Changes the illumination color gradually.

TODAY'S COLOR #* DAILY: Changes the illumination color every day. You can select which color to start with. (See "To select TODAY'S COLOR" to the right column.)

- * The color number of TODAY'S COLOR is selected from COLOR 1 – 7.

COLOR 1 – 7: You can adjust and register the color from COLOR 1 to 7. (See "To adjust and register the color" to the right column.)

- If you press **COLOR** while the unit is turned off, the display illumination will start (see page 9.)



More on the display illumination

- The colors shown on the display cannot always be reproduced precisely. Due to the circumstances (room temperature, etc.) where the unit is used, colors may vary slightly.
- When you change the color of the display, the display may seem to move back and forth; this is a characteristic of this unit and is not a malfunction.
- When a strong light strikes the display, the display happens to become dark, but this is not a malfunction.

To adjust and register the color

You can adjust the color by changing the tone, whiteness, brightness, and register into COLOR 1 to 7.

- There is a time limit in doing the following steps. If the setting is canceled before you finish, start from step **1** again.

On the remote control ONLY:

- 1** Press **COLOR** repeatedly until the color number (COLOR 1 to 7) you want to adjust appears on the display.

The adjustment bars appear on the display.



- 2** Adjust the tone, whiteness, and brightness.

- 1) Press → or ← to select the level you want and press SET.**

- Each time you press **SET**, the adjustment items change.
- The tone can be adjusted in 14 patterns. The whiteness can be adjusted in 3 levels and the brightness can be adjusted in 2 levels.

- 2) Repeat 1) to adjust "WHITENESS" and "BRIGHTNESS."**

- If the whiteness is set to the right end, the tone you adjusted will be no longer valid.

To select "TODAY'S COLOR"

The illumination color changes automatically each time the built-in clock becomes "AM12:00."

- There is a time limit in doing the following steps. If the setting is canceled before you finish, start from step **1** again.

On the remote control ONLY:

- 1** Press **COLOR** repeatedly until "TODAY'S COLOR" appears on the display.

- 2** Press → or ← to select the color number (COLOR 1 to 7.)

To dim the display

This function can be used only while the unit is turned on.

On the remote control ONLY:

To dim the display, press **DIMMER**.

To brighten the display, press **DIMMER** again.

- Pressing **COLOR** also brightens the display.

Listening to FM and AM Broadcasts

Continued

The buttons emphasized in the illustration below are used and explained in this section (pages 15 to 16.)

Remote control

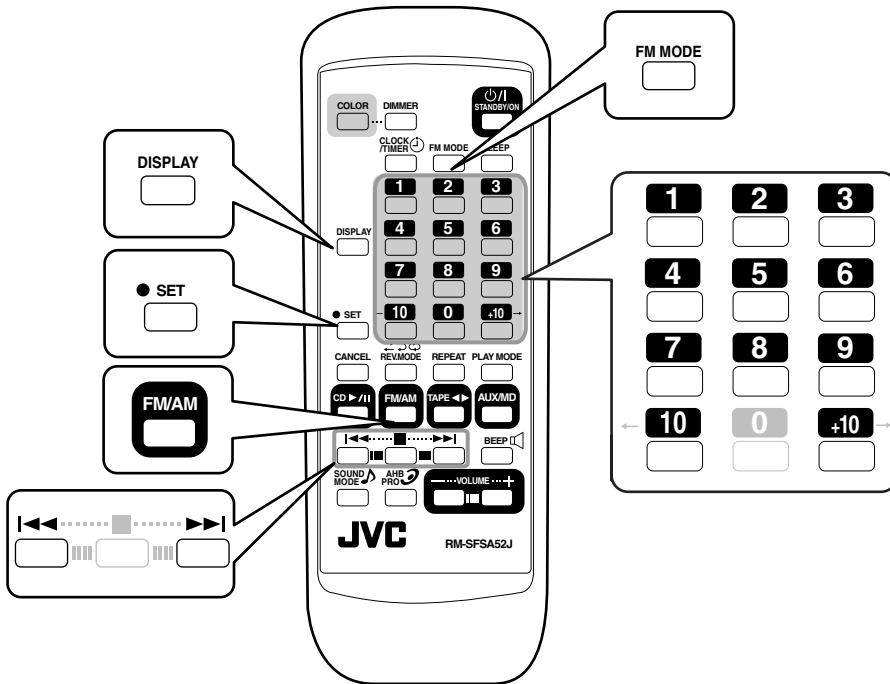

Main unit (Top view)

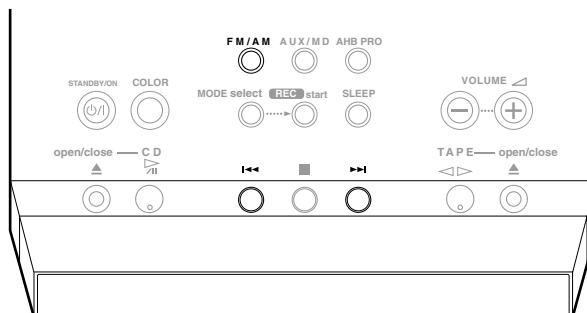

Tuning in a Station

1 Press FM/AM repeatedly to select “FM” or “AM.”

The unit automatically turns on with the last selected station.

- Each time you press the button, the band alternates between FM and AM.

2 Press and hold ►► or ◄◄ until the station frequencies start changing on the display.

- ►►: to increase the frequencies.
- ◄◄: to decrease the frequencies.

The unit starts searching stations and stops when a station of sufficient signal strength is tuned in.

FM
87.5 MHz

Ex. An FM station is tuned in.

- If an FM program is broadcast in stereo, the ST (stereo) indicator lights on the display.

To stop during searching, press ►► or ◄◄.



When you press ►► or ◄◄ repeatedly the frequency changes step by step.

To change the FM reception mode

When an FM stereo broadcast is noisy or hard to receive, you can change the FM reception mode to improve the reception.

On the remote control ONLY:

Press FM MODE so that the MONO indicator lights on the display.

- Each time you press the button, the MONO indicator lights and goes off alternately.

When the MONO indicator is lit:

Reception improves though stereo effect is lost.

When the MONO indicator is not lit:

You can hear stereo sound when a program is broadcast in stereo.

The ST (stereo) indicator lights while receiving the FM stereo broadcast (only when the reception is good.)

In addition, static noise between stations will be erased while tuning.

Presetting Stations

You can preset 30 FM and 15 AM stations manually.

In some cases, test frequencies have been already memorized for the tuner since the factory examined the tuner preset function before shipment. This is not a malfunction. You can preset the stations you want into memory by following the presetting method.

- There is a time limit in doing the following steps. If the setting is canceled before you finish, start from step 2 again.

On the remote control ONLY:

1 Tune in a station you want to preset.

- See “Tuning in a Station” to the left column.

2 Press SET.

The preset number starts flashing as follows:

- When you select an FM station in step 1

FM-P 1

- When you select an AM station in step 1

AM-P 1

Preset No. 1 always appears at first.

3 Press the number buttons to select a preset number.

Ex. For preset number 5, press 5.

For preset number 15, press +10, then 5.

For preset number 20, press +10, then 10.

For preset number 30, press +10, +10, then 10.

- You can also select the preset number by pressing ►► or ◄◄.

4 Press SET again.

“STORED” appears on the display for a while.

STORED

The tuned station in step 1 is stored in the preset number selected in step 3.

- Storing a new station on a used number erases the previously stored one.



When you unplug the AC power cord or if a power failure occurs

The preset stations will be erased. If this happens, preset the stations again.

Tuning in a Preset Station

On the remote control ONLY:

1 Press FM/AM repeatedly to select “FM” or “AM.”

The unit automatically turns on with the last selected station.

- Each time you press the button, the band alternates between FM and AM.

2 Press the number buttons to select a preset number.

Ex. For preset number 5, press 5.

For preset number 15, press +10, then 5.

For preset number 20, press +10, then 10.

For preset number 30, press +10, +10, then 10.

To check the clock time while listening to the broadcast

On the remote control ONLY:

Press **DISPLAY** (not on number buttons.)

- Each time you press the button, the source information and the clock time alternate on the display.

Playing Back a CD

The buttons emphasized in the illustration below are used and explained in this section (pages 18 to 21.)

Remote control

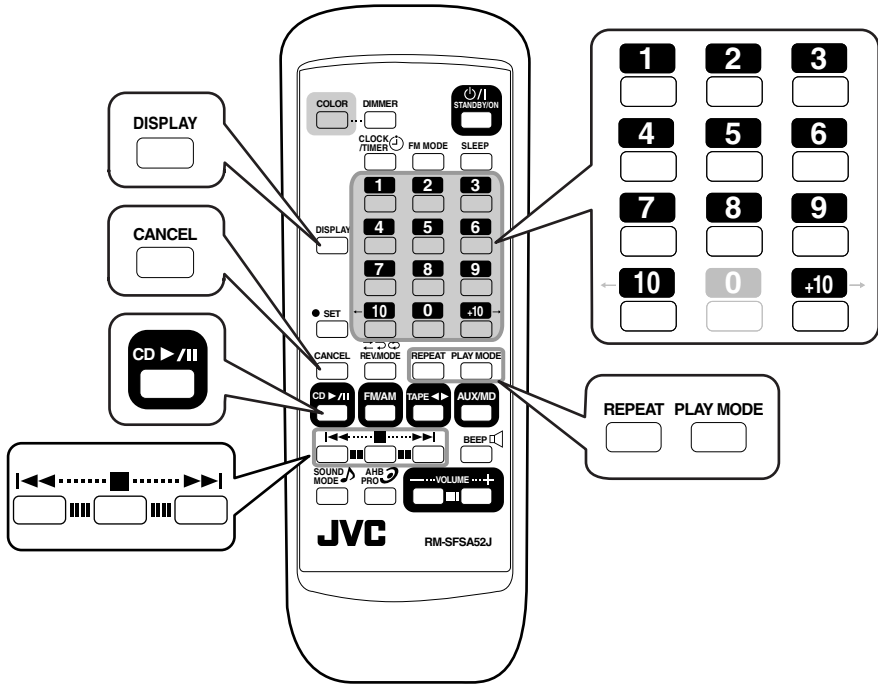

Main unit (Top view)

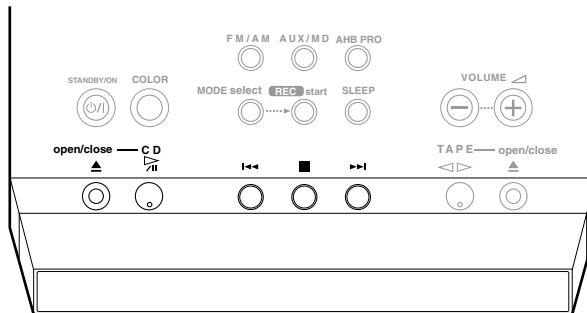

Precautions on CD Playback

This unit has been designed to play back discs bearing the following logos:



CD ReWritable (CD-RW)



CD Recordable (CD-R)



Audio CD

When playing a CD-R or CD-RW

User-edited CD-Rs (CD-Recordable) and CD-RWs (CD-ReWritable) can be played back when they are already **“finalized.”** If you play back an **unfinalized** disc, “UNFINALIZE” appears on the display.

- You can play back your original CD-Rs or CD-RWs recorded in **music CD format ONLY**. (If CD-RWs have been recorded in different format, erase all the data on CD-RWs completely before re-recording on the discs.)



DO NOT play back CD-Rs or CD-RWs including the sound files such as MP3.

- Before playing back CD-Rs or CD-RWs, read their instructions or cautions carefully.
- Some CD-Rs or CD-RWs may not be played back on this unit because of their disc characteristics, damage or stain on them, or if the player’s lens is dirty.

Important notices:

- In general, you will have the best performance by keeping your CDs and the mechanism clean.
 - Store CDs in their cases, and keep them in cabinets or on shelves.
 - Keep the unit’s disc tray closed when not in use.
- Continuous use of irregular shaped discs (heart-shape, octagonal, etc.) can damage the disc rotating mechanism.

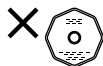

- CD-RWs may require a longer readout time. This is caused by the fact that the reflectance of CD-RWs is lower than for regular CDs.

Playing Back the Entire CD—Normal Play

You can play a CD.

1 Press CD open/close ▲ on the unit.

The unit automatically turns on, the electronic swing panel slides upward, and the disc tray comes out.

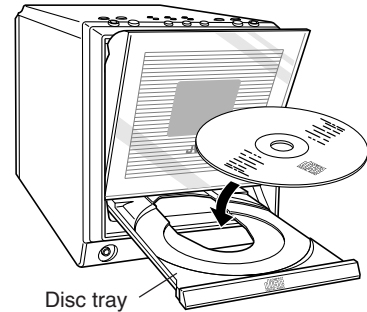

Disc tray

2 Place a CD correctly on the circle of the disc tray with its label side up.

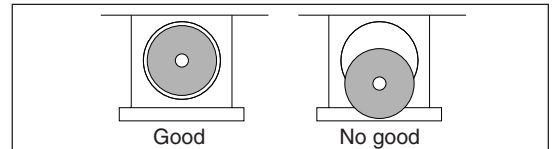

- When using a CD single (8 cm), place it on the inner circle of the disc tray.

3 Press CD ► / II.

The disc tray closes, then the electronic swing panel slides downward automatically.

The CD indicator starts rotating on the display and CD playback starts from the first track.

- If you press CD open/close ▲ again, the disc tray closes, and the electronic swing panel slides downward automatically. CD playback does not start until you press CD ► / II.

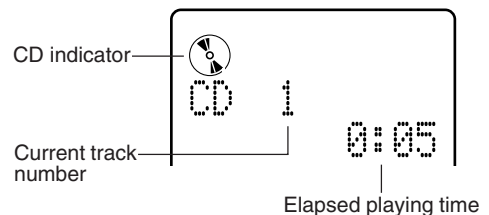

CD playback stops automatically after playing all the tracks on the CD.

To stop during play, press ■.

The following information appears.

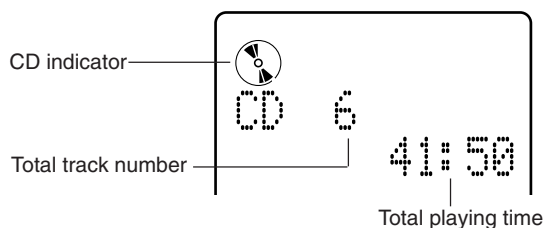

To remove the disc, press CD open/close ▲.

The electronic swing panel slides upward, and the disc tray comes out.

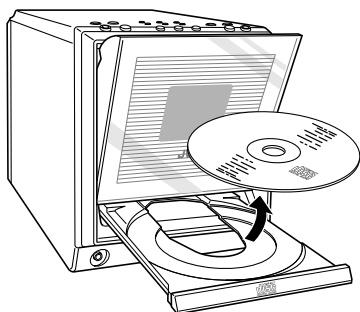

- After removing the CD, press CD open/close ▲ again to close the electronic swing panel.

Basic CD Operations

While playing a CD, you can do the following operations.

To stop playback for a moment

Press CD ► / ||.

The elapsed playing time starts flashing on the display.

To resume playback, press CD ► / || again.

To locate a particular point in a track during play

Press and hold ►► or ◀◀.

- ►►: Fast-forwards the tracks.
- ◀◀: Fast-reverses the tracks.

To go to another track

Press ►► or ◀◀ repeatedly.

- ►►: Skips to the beginning of the next or succeeding tracks.
- ◀◀: Goes back to the beginning of the current or previous tracks.

To go to another track directly using the number buttons

On the remote control ONLY:

Pressing the number button(s) allows you to start playing the track number you want.

- Ex.: For track number 5, press 5.
- For track number 15, press +10, then 5.
- For track number 20, press +10, then 10.
- For track number 32, press +10, +10, +10, then 2.

To check the clock time while playing back CD

On the remote control ONLY:

Press DISPLAY (not on number buttons.)

- Each time you press the button, the source information and the clock time alternate on the display.

Programming the Playing Order of the Tracks —Program Play

You can arrange the order in which the tracks play before you start playing. You can program up to 32 tracks.

On the remote control ONLY:

- 1** Load a CD.
- 2** Press **CD ▶ / II**, then **■**.
The source is changed to “CD.”
- 3** Press **PLAY MODE** repeatedly until “PROGRAM” appears on the display.

- Each time you press the button, play mode changes as follows:

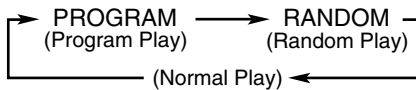

- 4** Press the number buttons to select the tracks.

- For how to use the number buttons, see “To go to another track directly using the number buttons” on page 19.

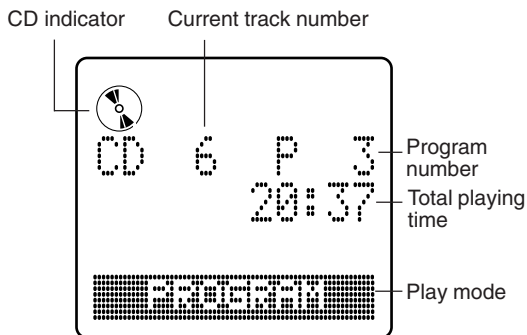

- 5** Press **CD ▶ / II**.

- The tracks are played in the order you have programmed.
- Program Play ends when all the tracks are played once.

To stop during play, press ■.

To exit from Program Play, press PLAY MODE repeatedly so that the unit enters the other play modes (Random Play or Normal Play) before or after play.

To check the program contents

Before playing, you can check the program contents by pressing **◀◀** or **▶▶**.

- **◀◀**: Shows the programmed tracks in the reverse order.
- **▶▶**: Shows tracks in the programmed order.

To modify the program

Before or after playing, you can erase the last programmed track by pressing **CANCEL**. Each time you press the button, the last programmed track is erased from the program.

To add tracks in the program before you start play, press the number buttons to select track numbers you want to add.

To erase the entire program, press CD open/close ▲ to eject the CD.

- Turning off the unit will also erase the program.



If you try to program a 33rd step “MEMORY FULL” will appear on the display.



If your entry is ignored
You have tried to program a track number that does not exist on the CD (for example, selecting track 14 on a CD that only has 12 tracks.) Such entries are ignored.



If the total playing time is 100 minutes (one hour and 40 minutes) or more
The total playing time will not be shown. (“--:--” will appear.)

Playing at Random—Random Play

The tracks of a loaded CD will play at random.

On the remote control ONLY:

- 1 Load a CD.
- 2 Press CD ► / II, then ■.
The source is changed to “CD.”
- 3 Press PLAY MODE repeatedly until “RANDOM” appears on the display.
 - Each time you press the button, play mode changes as follows:

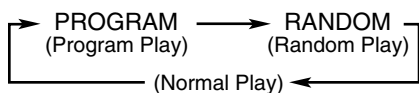

- 4 Press CD ► / II.
The tracks are played at random.

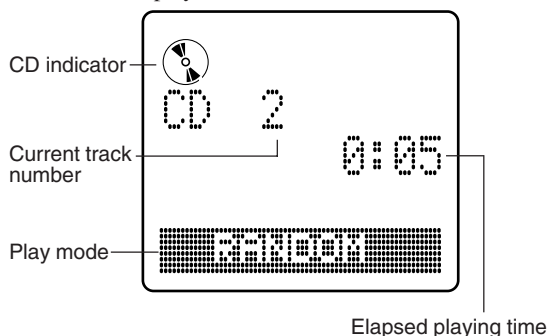

Random Play stops when all the tracks are played once.

To skip the current track, press ►►.

- You cannot go back to the previous tracks by pressing ◀◀.

To stop during play, press ■.

To exit from Random Play, press PLAY MODE repeatedly so that the unit enters the other play modes (Normal Play or Program Play) before or after play.

Repeating Tracks—Repeat Play

You can repeat all tracks (regardless of play mode), or also a single track as many times as you like.

On the remote control ONLY:

To repeat play, press REPEAT before or during play.

- Each time you press the button, Repeat Play changes as follows:

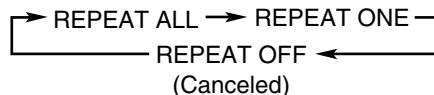

REPEAT ALL : Repeats all the tracks on the CD (in Normal or Random Play), or all the tracks in Program Play.

REPEAT ONE : Repeats only one track.

REPEAT OFF : Cancels Repeat Play.

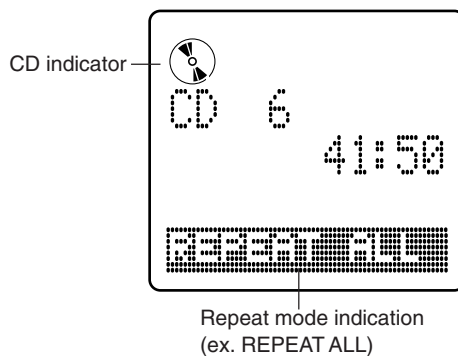

- If play mode is either Program or Random Play, the repeat mode indication appears on the display for a while each time you press REPEAT.

To exit from Repeat Play, press REPEAT repeatedly until “REPEAT OFF” appears on the display.

Playing Back a Tape

Continued 

The buttons emphasized in the illustration below are used and explained in this section (page 23.)

Remote control

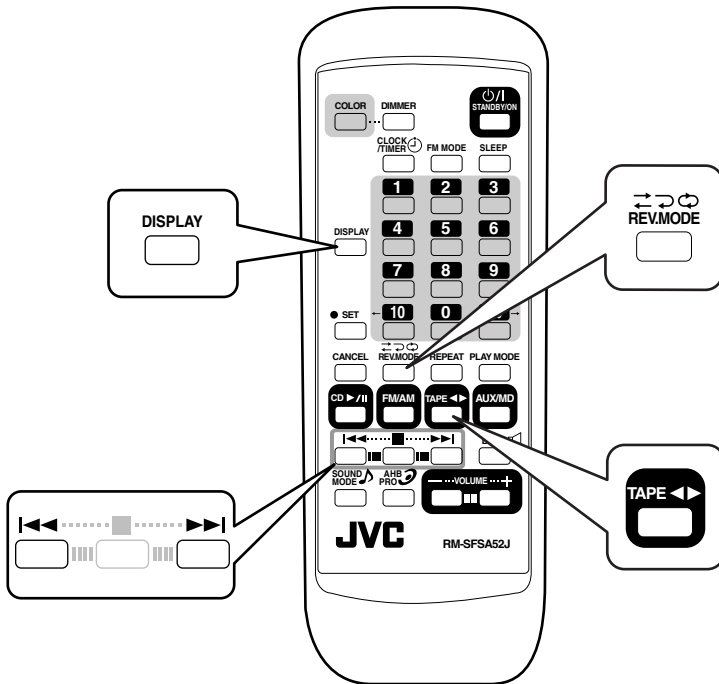

Main unit (Top view)

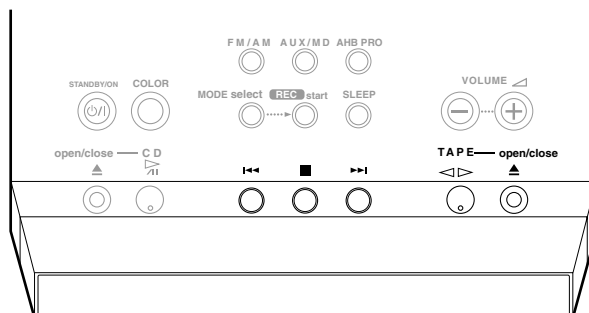

Playing Back a Tape

You can play back type I, II, and IV tapes.

1 Press TAPE open/close \blacktriangle on the unit.

The unit automatically turns on, the electronic swing panel slides downward, and the cassette loading slot appears.

If a cassette is already in the cassette loading slot, it is ejected.

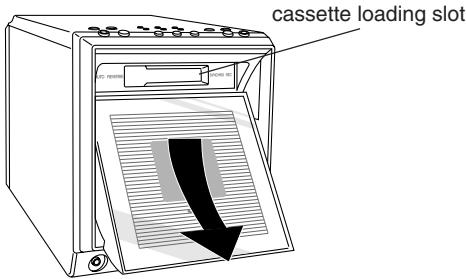

2 Insert a cassette with the exposed part facing left.

The cassette is pulled in, then the electronic swing panel slides upward automatically.

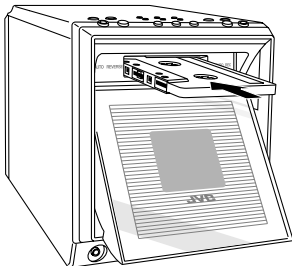

3 Press TAPE $\blacktriangle\blacktriangleleft$.

The tape starts playing.

- Each time you press the button, the tape direction changes as follows:

$\blacktriangle\blacktriangleleft$: Plays the front side.

$\blacktriangle\blacktriangleright$: Plays the reverse side.

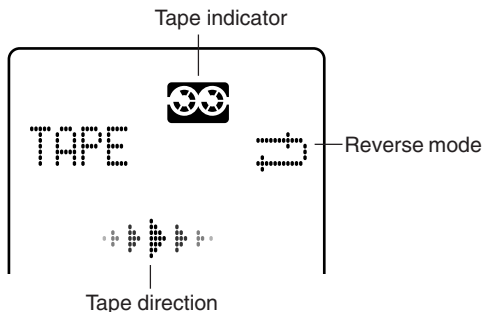

When the tape plays to the end, the cassette deck automatically stops if the reverse mode is set to $\blacktriangle\blacktriangleright$ or $\blacktriangle\blacktriangleright$. (See "To play both sides—Reverse Mode".)

To stop during play, press ■.

To fast-wind or rewind the tape, press $\blacktriangle\blacktriangle\blacktriangle$ or $\blacktriangle\blacktriangle\blacktriangleleft$.

- When the tape direction is $\blacktriangle\blacktriangle\blacktriangle$

$\blacktriangle\blacktriangle\blacktriangle$: Fast-winds the tape.

$\blacktriangle\blacktriangle\blacktriangleleft$: Rewinds the tape.

- When the tape direction is $\blacktriangle\blacktriangle\blacktriangleleft$

$\blacktriangle\blacktriangle\blacktriangleleft$: Fast-winds the tape.

$\blacktriangle\blacktriangle\blacktriangle$: Rewinds the tape.

To eject the cassette, press TAPE open/close \blacktriangle .

- After ejecting the cassette, press TAPE open/close \blacktriangle again to close the electronic swing panel.



DO NOT press TAPE open/close \blacktriangle during tape play.

To play both sides—Reverse Mode

You can set the cassette deck to play just one side of a tape, both sides once, or both sides continuously.

- You can set this mode only when a cassette is already in the cassette deck.

On the remote control ONLY:

Press REV. MODE.

- Each time you press the button, the reverse mode changes as follows:

$\blacktriangle\blacktriangleleft$: To only play back one side (front or reverse.)

$\blacktriangle\blacktriangleleft$ $\blacktriangle\blacktriangleright$: To play back the front and reverse sides once.

$\blacktriangle\blacktriangleleft$ $\blacktriangle\blacktriangleright$ $\blacktriangle\blacktriangleleft$: To play back both front and reverse sides continuously.

To check the clock time while playing back a tape

On the remote control ONLY:

Press DISPLAY (not on number buttons.)

- Each time you press the button, the source information and the clock time alternate on the display.



The use of the C-120 or thinner tape is not recommended, since characteristic deterioration may occur and this tape easily jams in the pinch rollers and the capstans.

Using External Equipment

Continued 

The buttons emphasized in the illustration below are used and explained in this section (page 25.)

Remote control

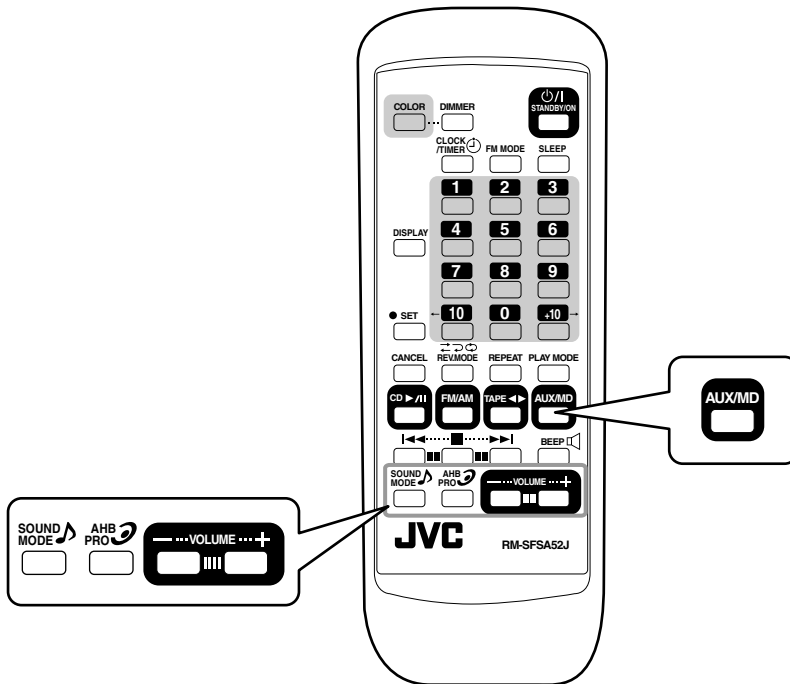

Main unit (Top view)

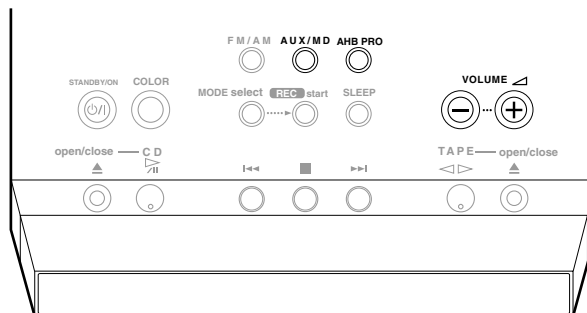

Listening to External Equipment

You can listen to external equipment such as an MD recorder.

- First make sure that the external equipment is properly connected as follows:

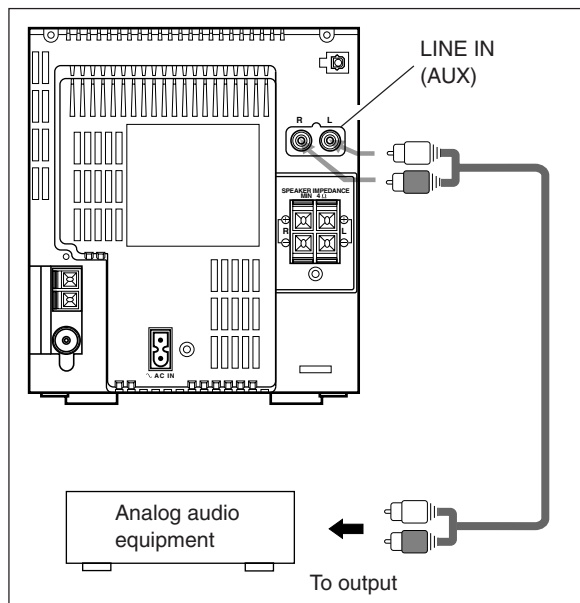

1 Press AUX/MD.

“AUX” appears on the display.

AUX

2 Adjust the volume level to the minimum position.

3 Start playing the external equipment.

- For operation of the external equipment, refer to its manual.

4 Press VOLUME + / - to adjust your desired listening level.

5 Apply sound effects, if you wish.

- Press AHB PRO if you want to reinforce the bass sound.
(See “Reinforcing the Bass sound” on page 12.)
- Press SOUND MODE if you want to control the tone.
(See “Selecting the Sound modes” on page 12.)

Recording from This Unit to External Equipment

You can record from this unit to external equipment connected to the OPTICAL DIGITAL OUT terminal of this unit, such as an MD recorder.

- The recording level is not affected by the VOLUME level and sound effect, either.
- First make sure that the external equipment is properly connected as follows:

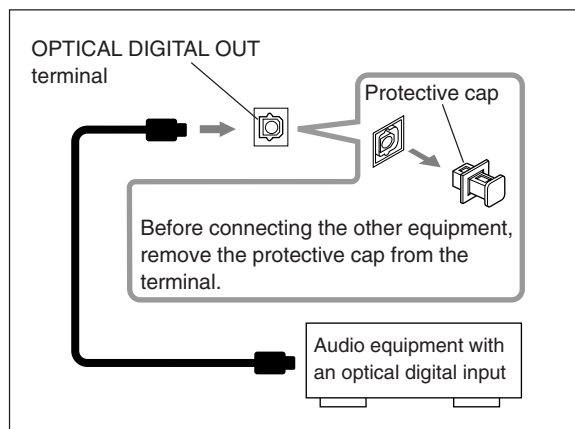

1 Prepare for recording on the external equipment.

2 Start recording on the external equipment.

- For operation of the external equipment, refer to its manual.

3 Play the CD Player of this unit.

- For the CD operation, see page 17 to 21.

To check the clock time while listening to the external equipment

On the remote control ONLY:

Press DISPLAY (not on number buttons.)

- Each time you press the button, “AUX” and the clock time alternate on the display.

Recording on Tapes

Continued 

The buttons emphasized in the illustration below are used and explained in this section (pages 28 to 29.)
For recording operations, mainly use the buttons on the unit.

Main unit (Top view)

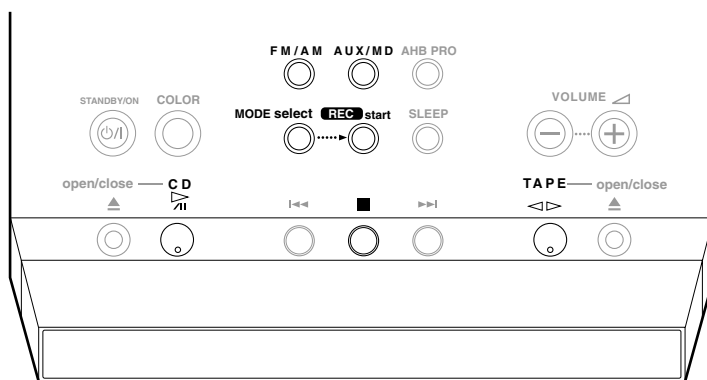

Remote control

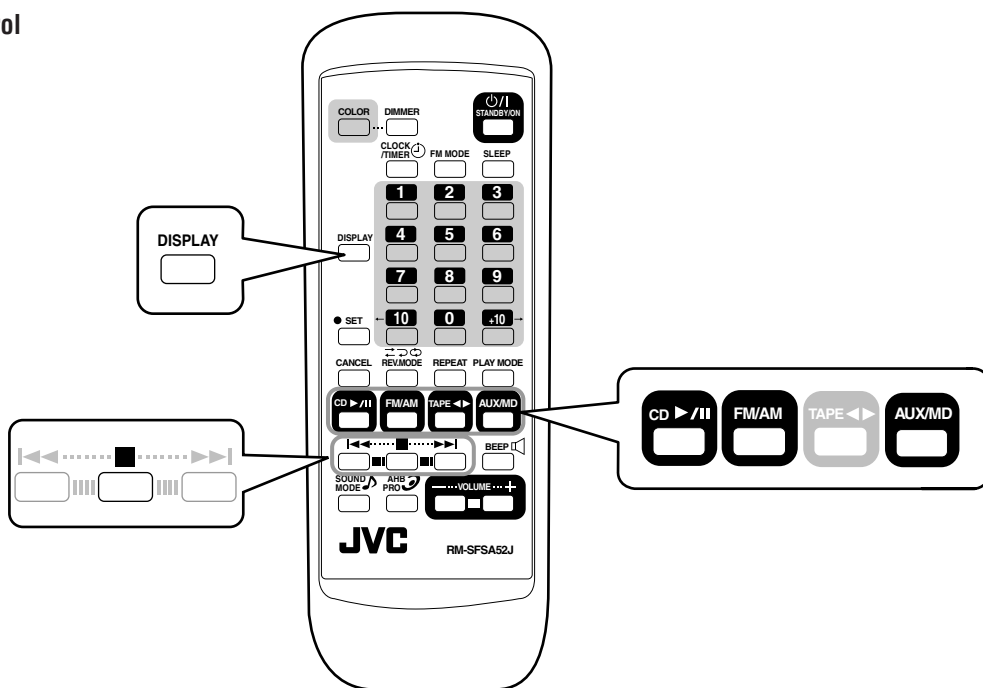

Before You Start Recording

- It should be noted that it may be unlawful to re-record pre-recorded tapes, records, or discs without the consent of the owner of copyright in the sound or video recording, broadcast or cable programme and in any literary, dramatic, musical, or artistic embodied therein.
- The recording level is automatically set correctly, so it is not affected by the VOLUME control. Thus, during recording you can adjust the sound you are actually listening to without affecting the recording level.
- While recording, you can hear sound mode effect and/or the Active Hyper Bass PRO effect through the speakers or headphones. However, the sound is recorded without these effects (see pages 12.)
- While recording, the display lights red.
- If recordings you have made have excessive noise or static, the unit may be too close to a TV. Place the unit away from the TV.
- You can use type I tape for recording.

To protect your recordings

Cassettes have two small tabs on the back to protect unexpected erasure or recording.

To protect your recording, remove these tabs.

To re-record on a protected tape, cover the holes with adhesive tape.



The use of the C-120 or thinner tape is not recommended, since characteristic deterioration may occur and this tape easily jams in the pinch rollers and the capstans.

To keep the best recording and playback sound quality

You need to clean the heads.

- Clean the heads after every 10 hours of use with a wet-type head cleaning tape (available at electronic and audio shops.)
When the head becomes dirty, the following symptoms will occur:
 - Sound quality is reduced.
 - Sound level decreases.
 - Sound drops out.
- Do not play dirty or dusty tapes.
- Do not touch the highly-polished head with any metallic or magnetic tools.

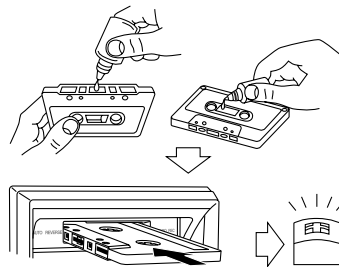

To demagnetize the head

Turn off the unit, and use a head demagnetizer (available at electronic and audio shops.)





At the start and end of cassette tapes

There is leader tape which cannot be recorded onto. Thus, when recording CDs or radio broadcasts, wind the leader tape first to ensure that the recording will be made without any music part lost.

What's a Recording Mode and Reverse Mode ?

You have two methods (MODE 1/2 and 2/2) to record from some sources onto a tape.

Recording mode	Reverse mode
MODE 1/2	
MODE 2/2	

 : To record the front and reverse sides once.

 : To only record one side (front or reverse.)

In the following procedure, MODE 1/2 () is selected as a recording method.

Recording FM/AM Broadcasts

You can record from an FM or AM broadcast onto a tape.

On the unit ONLY:

1 Insert a recordable cassette into the cassette loading slot.

- Press TAPE <▷> to adjust the tape direction to “” then ■.

2 Tune in a station you want.

- For more detailed operations, see pages 15 and 16.

3 Press MODE select to select a recording mode.

- Each time you press the button, recording mode changes as follows:

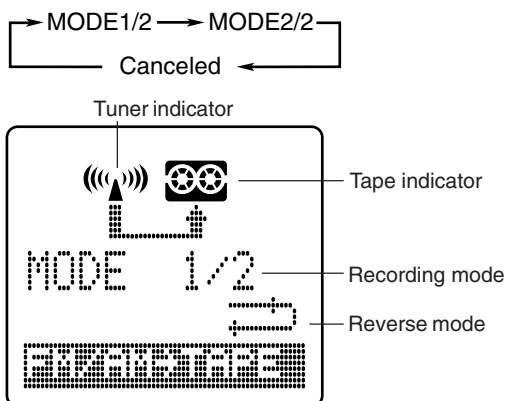

Ex. When selecting MODE 1/2

4 Press REC start.

- The recording starts.

To stop recording, press ■.

To check the clock time while recording from the broadcast onto a tape

On the remote control ONLY:

Press DISPLAY (not on number buttons.)

- Each time you press the button, the recording information and the clock time alternate on the display.

Recording CD—CD Synchronized Recording

You can record from a CD onto a tape.

Using these synchronized recording methods, you can start and stop CD play and tape recording at the same time.

On the unit ONLY:

1 Insert a recordable cassette into the cassette loading slot.

- Press TAPE <▷> to adjust the tape direction to “” then ■.

2 Prepare a CD.

- After loading the CD, press CD ▷ / ■, then ■ before going to the next step.
- You can make a program (see page 20) or select Random Play (see page 21) if you want.

3 Press MODE select to select a recording mode.

- Each time you press the button, recording mode changes as follows:

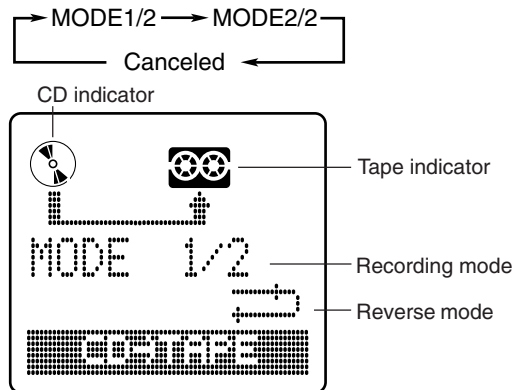

Ex. When selecting MODE 1/2

4 Press REC start.

Both the CD play and the recording start.

- After the recording, both the CD player and the cassette deck stop automatically.

To stop recording, press ■.

CD play stops first, then after 4 seconds, the recording stops.

To record a single track during play or pause

While playing back you want to record, perform steps **3** and **4**.

The playback of the track is stopped, and then starts from the beginning again. This time, the cassette deck starts recording the track.

- After the track is recorded, both the CD player and the cassette deck stop automatically.

To check the clock time while recording from the CD onto a tape

On the remote control ONLY:

Press **DISPLAY** (not on number buttons.)

- Each time you press the button, the recording information and the clock time alternate on the display.

Recording External Equipment

You can record from external equipment onto a tape. The external equipment needs to be connected to LINE IN (AUX) terminal of this unit (for how to connect, see page 9.)

On the unit ONLY:

- 1** Insert a recordable cassette into the cassette loading slot.

- Press **TAPE** < > to adjust the tape direction to “” then **■**.

- 2** Press **AUX/MD**.

- The source is changed to “AUX.”

- 3** Press **MODE** select to select a recording mode.

- Each time you press the button, recording mode changes as follows:

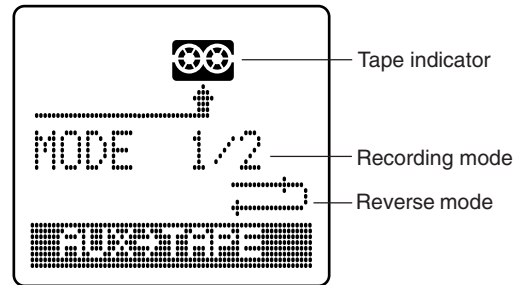
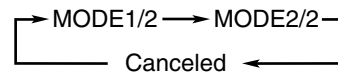

Ex. When selecting MODE 1/2

- 4** Press **REC** start.

- The recording starts.

- 5** Start playback on the external equipment.

To stop recording, press **■**.

To check the clock time while recording from the external equipment onto a tape

On the remote control ONLY:

Press **DISPLAY** (not on number buttons.)

- Each time you press the button, the recording information and the clock time alternate on the display.

The buttons emphasized in the illustration below are used and explained in this section (pages 31 to 34.)

Remote control

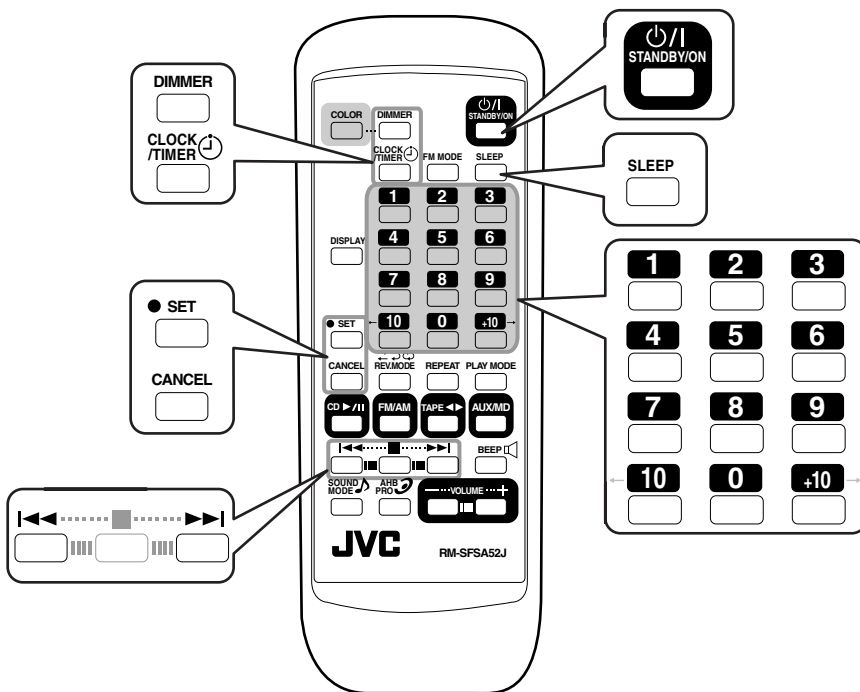

Main unit (Top view)

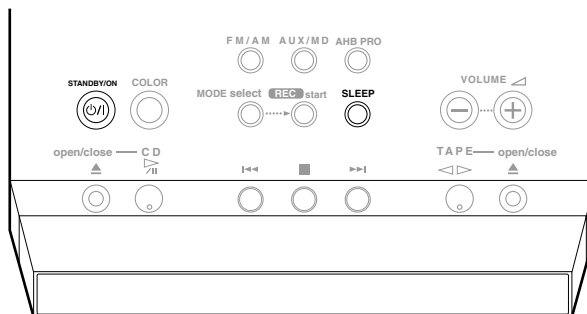

There are three timers available—Recording Timer, Daily Timer, and Sleep Timer.

You need to set the built-in clock to use these timers.

Setting the Clock

You can set the clock whether the unit is turned on or off (on standby.)

On the remote control ONLY:

- 1 Press CLOCK/TIMER repeatedly until “TIME ADJUST” appears on the display.**

The hour digit starts flashing on the display.



- 2 Press ►► or ◀◀ repeatedly to adjust the hour.**

- When you press and hold the button, the hour digit changes continuously.

- 3 Press SET to set the hour.**

The minute digit starts flashing on the display.



Ex. When pressing SET after adjusting the hour to 10.

- If you want to correct the hour again, press CANCEL.

The hour digit starts flashing again.

- 4 Press ►► or ◀◀ repeatedly to adjust the minute.**

- When you press and hold the button, the minute digit changes continuously.

- 5 Press SET to finish setting the clock.**

The built-in clock starts.



Ex. When pressing SET after adjusting the minute to 10.



To adjust the clock again

Press CLOCK/TIMER repeatedly in step 1 until “TIME ADJUST” appears on the display, then perform steps 2 to 5 above.



To check the clock time by sound while the unit is turned off (on standby)

Press DIMMER while the key-touch tone is set to on. The clock time will be indicated by sound.



When you unplug the AC power cord or if a power failure occurs

The clock setting will be reset to “AM12:00.” If this happens, you need to set the clock again.

Using Recording Timer

With Recording Timer, you can make an unattended recording.

- You can set Recording Timer whether the unit is turned on or off (on standby.)
- To correct a misentry any time during the setting process, press CANCEL.

How Recording Timer actually works

The unit automatically turns on, and starts recording on a tape when the timer-on time comes. (While Recording Timer is working, the REC indicator keeps flashing.) Then, when the timer-off time comes, the recording stops and the unit automatically turns off (on standby.)

Recording Timer works only once, but the timer settings remain stored in memory unless you reset them or unplug the AC power cord.

On the remote control ONLY:

- 1 Press CLOCK/TIMER repeatedly until “REC TIMER” appears on the display.**

The timer (⌚) indicator lights, and the REC indicator starts flashing on the display.

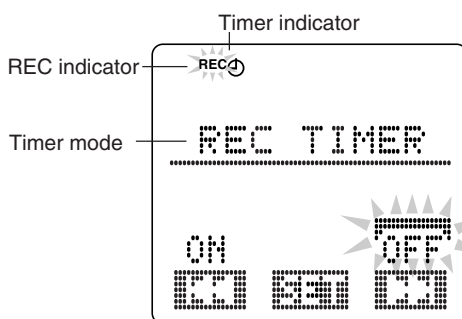

- Each time you press the button, the timer mode changes as follows:

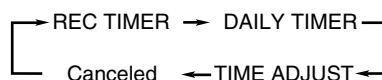

2 Press **◀◀** to select “ON,” then press **SET**.

3 Select the source to record.

1) Press **▶▶** or **◀◀** repeatedly to select the source.

- Each time you press the buttons, the source changes as follows:

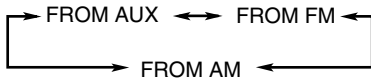

2) Press **SET**.

- When you have selected “FROM FM” or “FROM AM,” select a preset number by pressing **▶▶** or **◀◀** (for how to preset stations, see page 15.)
- When you have selected “FROM AUX,” the external equipment also needs to have the timer function.

3) Press **SET** again.

4 Select the reverse mode either **↔** or **↔** by pressing **▶▶** or **◀◀**, then press **SET**.

- For reverse mode, see page 28.

5 Set the timer-on and timer-off time.

1) Press **▶▶** or **◀◀** repeatedly to select the hour of the timer-on time, then press **SET**.

The minute digit of timer-on time starts flashing on the display.

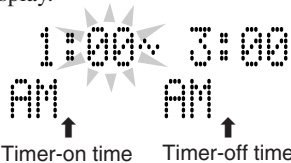

2) Press **▶▶** or **◀◀** repeatedly to select the minute of the timer-on time, then press **SET**.

The hour digit of timer-off time starts flashing on the display.

3) Press **▶▶** or **◀◀** repeatedly to select the hour of the timer-off time, then press **SET**.

The minute digit of timer-off time starts flashing on the display.

4) Press **▶▶** or **◀◀** repeatedly to select the minute of the timer-off time, then press **SET**.

- The setting you have done are shown on the display in sequence.
- The REC indicator stops flashing and remains lit.

6 Press **⏻** STANDBY/ON to turn off the unit (on standby) if necessary.

- No sounds come out while timer recording is performed.

To turn off the Recording Timer after its setting is done,

1 Press **CLOCK/TIMER** repeatedly until “REC TIMER” appears on the display.

2 Press **▶▶** to select “OFF,” then press **SET**.

The timer (⌚) and REC indicators go off from the display.

To turn on the Recording Timer again, press **◀◀** to select “ON,” then press **SET**.

The timer (⌚) and REC indicators light on the display.

The settings you have done are shown on the display for your confirmation.



notes If you stop recording during Recording Timer

The recording is canceled, but when the timer-off time comes, the unit turns off.



notes When you unplug the AC power cord or if a power failure occurs

The timer setting, the tuner preset stations and other settings will be erased.

Using Daily Timer

With Daily Timer, you can wake up to your favorite music or radio program.

- You can set Daily Timer whether the unit is turned on or off (on standby.)
- To correct a misentry any time during the setting process, press **CANCEL**.

How Daily Timer actually works

The unit automatically turns on, and starts playing the specified source when the timer-on time comes. (While Daily Timer is working, the DAILY indicator keeps flashing.) Then, when the timer-off time comes, the unit automatically turns off (on standby.)

Daily Timer works every day, and the timer settings remain stored in memory unless you reset them or unplug the AC power cord.

On the remote control ONLY:

1 Press **CLOCK/TIMER** repeatedly until **“DAILY TIMER”** appears on the display.

The timer (⌚) indicator lights, and the **DAILY** indicator starts flashing on the display.

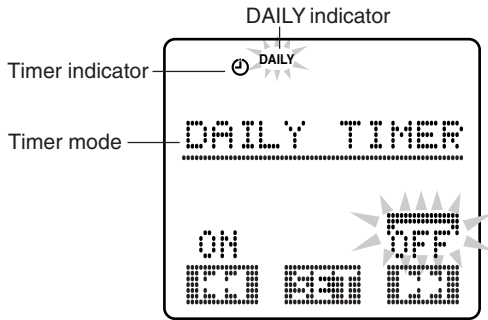

- Each time you press the button, the timer mode changes as follows:

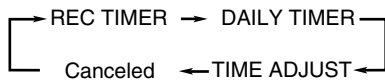

2 Press **◀** to select **“ON,”** then press **SET**.

3 Select the source to play.

- 1) Press **▶▶** or **◀◀** repeatedly to select the source.
 - Each time you press the buttons, the source changes as follows:



2) Press **SET**.

- When you have selected **“FROM FM”** or **“FROM AM,”** select a preset number by pressing **▶▶** or **◀◀** (for how to preset stations, see page 15.)
- When you have selected **“FROM AUX,”** the external equipment also needs to have the timer function.

3) Press **SET** again.

4 Set the timer-on and timer-off time.

- 1) Press **▶▶** or **◀◀** repeatedly to select the hour of the timer-on time, then press **SET**.

The minute digit of timer-on time starts flashing on the display.

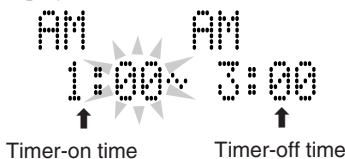

- 2) Press **▶▶** or **◀◀** repeatedly to select the minute of the timer-on time, then press **SET**.

The hour digit of timer-off time starts flashing on the display.

- 3) Press **▶▶** or **◀◀** repeatedly to select the hour of the timer-off time, then press **SET**.

The minute digit of timer-off time starts flashing on the display.

- 4) Press **▶▶** or **◀◀** repeatedly to select the minute of the timer-off time, then press **SET**.

5 Adjust the volume level.

- 1) Press **▶▶** or **◀◀** repeatedly to adjust the volume level.

- You can adjust the volume level within the range of 0 (silent) to 40 (maximum.)
- When you select **“VOLUME –,”** the volume is set to the current volume level.

- 2) Press **SET**.

- The settings you have done are shown on the display in sequence.
- The **DAILY** indicator stops flashing and remains lit on the display.

6 Press **⏻/STANDBY/ON** to turn off the unit (on standby.)

To turn off the Daily Timer after its setting is done,

- 1) Press **CLOCK/TIMER** repeatedly until **“DAILY TIMER”** appears on the display.

- 2) Press **▶▶** to select **“OFF,”** then press **SET**.

The timer (⌚) and **DAILY** indicators go off from the display.

To turn on the Daily Timer again, press **◀** to select **“ON,”** then press **SET**.

The timer (⌚) and **DAILY** indicators light on the display.

The settings you have done are shown on the display for your confirmation.



If the unit is kept turned on until the timer-on time comes

Daily Timer does not work at all.



Daily Timer will be canceled and the unit will not turn off automatically in the following:

- When you change the source.



When you unplug the AC power cord or if a power failure occurs

The timer setting, the tuner preset stations and other settings will be erased.

Using Sleep Timer

With Sleep Timer, you can fall asleep to your favorite music.

- You can set Sleep Timer while the unit is turned on.

How Sleep Timer actually works

The unit automatically turns off after the specified time length passes.

- Press SLEEP repeatedly until the time length you want appears on the display.

The timer (⌚) indicator starts flashing and “SLEEP 10” appears on the display.

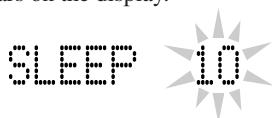

- Each time you press the button, the time length changes as follows:

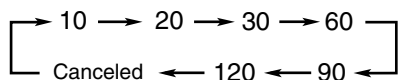

- Press SET or wait for about 5 seconds.

The display dims.

“SLEEP” appears on the display.

To check the remaining time until the shut-off time, press SLEEP once. The remaining time until the shut-off time appears for about 5 seconds.

To change the shut-off time, press SLEEP repeatedly until the time length you want appears.

To cancel the setting, press SLEEP repeatedly until “SLEEP” disappears from the display.



Sleep Timer will be canceled in the following:

- When you turn off the unit.
- When you operate other timer settings.
- When you adjust the clock.



If “CLOCK ADJUST” appears on the display

You need to set the built-in clock (see page 31.)

To sleep with the Sleep Timer and wake up with the Daily Timer

The unit turns off when the shut-off time comes (set by the Sleep Timer), and turns on when the timer-on time comes (set by the Daily Timer.)

- Set the Daily Timer as explained on pages 32 and 33.
- Start playing back any source you want to listen to before sleep.
- Set the Sleep Timer.

Timer Priority

Since each timer can be set separately, you may wonder what happens if the setting for these timers overlaps. Here are the priorities for each timer.

- A timer with the later timer-on time has priority.**

If Recording Timer is set to come on while Daily Timer is operating, Daily Timer is canceled.

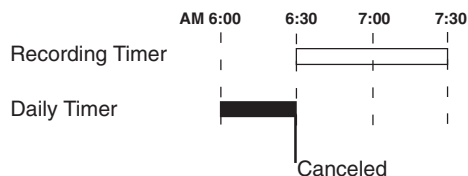

If Recording Timer is set to come on while Sleep Timer is operating, Sleep Timer will not shut off the power even if the shut-off time comes.

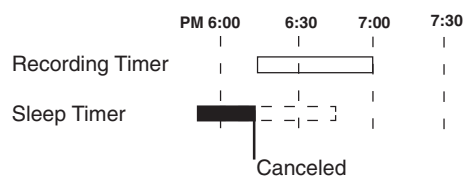

Maintenance

To get the best performance of the unit, keep your discs, tapes, and mechanism clean.

General Notes

In general, you will have the best performance by keeping your discs and the mechanism clean.

- Store discs in their cases, and keep them in cabinets or on shelves.
- Keep the electronic swing panel closed when not in use.

Cleaning the unit

• Stains on the unit

Should be wiped off with a soft cloth. If the unit is heavily stained, wipe it with a cloth soaked in water-diluted neutral detergent and wrung well, then wipe clean with a dry cloth.

• Avoid the following since they may cause damage to the unit.

- DO NOT wipe it with a hard cloth.
- DO NOT wipe it strong.
- DO NOT wipe it with thinner or benzine.
- DO NOT apply any volatile substance such as insecticides to it.
- DO NOT allow any rubber or plastic to remain in contact with it for a long time.

Handling discs



- Remove the disc from its case by holding it at the edge while pressing the center hole lightly.
- Do not touch the shiny surface of the disc, or bend the disc.
- Put the disc back in its case after use to prevent warping.

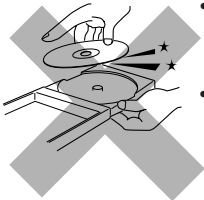

- Be careful not to scratch the surface of the disc when placing it back in its case.
- Avoid exposure to direct sunlight, temperature extremes and moisture.



To clean the disc

Wipe the disc with a soft cloth in a straight line from center to edge.

Handling cassette tapes

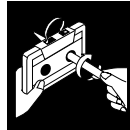

- If the tape is loose in its cassette, take up the slack by inserting a pencil in one of the reels and rotating.

- If the tape is loose, it may get stretched, cut, or caught in the cassette.



- Be careful not to touch the tape surface.



- Avoid the following places to store the tape:

- In dusty places
- In direct sunlight or heat
- In moist areas
- On a TV or speaker
- Near a magnet



DO NOT use any solvent—such as conventional record cleaner, spray, thinner, or benzine—to clean the disc.

Troubleshooting

If you are having a problem with your unit, check this list for a possible solution before calling for service. If you cannot solve the problem from the hints given here, or the unit has been physically damaged, call a qualified person, such as your dealer, for service.

Symptom	Possible Cause	Action
No sound is heard.	Connections are incorrect or loose.	Check all connections and make corrections. (See pages 6 – 9.)
Unable to operate the remote control.	<ul style="list-style-type: none"> The path between the remote control and the remote sensor on the unit is blocked. The batteries have lost their charge. You are using the remote control far from the unit. 	<ul style="list-style-type: none"> Remove the obstruction. Replace the batteries. (See page 6.) Signals cannot reach the remote sensor. Move closer to the unit.
Poor radio reception.	<ul style="list-style-type: none"> The antenna is not connected correctly. The AM loop antenna is too close to the unit. The FM antenna is not properly extended and positioned. 	<ul style="list-style-type: none"> Reconnect the antenna securely. Change the position and direction of the AM loop antenna. Extend FM antenna to the best reception position.
An inserted CD and cassette cannot be ejected.	The AC power cord is not plugged in.	Plug it in the AC power plug.
The CD does not play.	The CD is upside down.	Put the CD in with the label side up.
The CD skips.	The CD is dirty or scratched.	Clean or replace the CD. (See page 35.)
Impossible to record on a tape.	Small tabs on the back of the cassette are removed.	Cover the holes with adhesive tape.
Operations are disabled.	The built-in microprocessor has malfunctioned due to external electrical interference.	Unplug the unit then plug it back in.
If “CANNOT PLAY” appears on the display	You are trying to play back a CD which cannot be played or there is a problem with the CD.	Change the CD.
If “CD LOAD ERROR” appears on the display	The CD tray does not open correctly because of the obstruction.	Press CD open/close ▲ to close the CD tray, then remove the obstruction.
If “UNFINALIZE” appears on the display	You are trying to play back a CD-R/RW which has not been “finalized” yet.	This is not a malfunction. You can play back “finalized” CD-R/RWs.
Noise is heard during illumination demonstration mode.	This unit automatically turns off and on during demonstration. If volume level is set high, you will hear this noise.	Turn on the unit, decrease the volume, then turn it off again.

Specifications **FS-A52 (CA-FSA52 and SP-UXA52)**

Amplifier

Output Power:

40 W (20 W + 20 W) at 4 Ω (10 % THD)

Audio input sensitivity/Impedance (at 1 kHz)

LINE IN (AUX): 500 mV/47 kΩ

Digital output – OPTICAL DIGITAL OUT

Signal wave length: 660 nm

Output level: –21 dBm to –15 dBm

Speaker Terminals: 4 Ω — 16 Ω

Tuner

FM tuning range: 87.5 MHz — 108.0 MHz

AM tuning range: 530 kHz — 1 710 kHz

CD player

CD capacity: 1 CD

Dynamic range: 85 dB

Signal-to-noise ratio: 90 dB

Wow and flutter: Immeasurable

Cassette deck

Frequency response

Normal (type I): 60 Hz — 14 000 Hz

Wow and flutter

0.15 % (WRMS)

General

Power requirement: AC 120 V[~], 60 Hz

Power consumption: 45 W (at operation)

4.3 W (on standby)

Dimensions (approx.):

163 mm x 200 mm x 329 mm (W/H/D)

(6 ⁷/₁₆ in. x 7 ⁷/₈ in. x 13 in.)

Mass (approx.): 4.3 kg (9.5 lbs)

Speaker Section

Speakers: Woofer 10 cm, Tweeter 4 cm

Impedance: 4 Ω

Dimensions (approx.):

140 mm x 200 mm x 249 mm (W/H/D)

(5 ⁹/₁₆ in. x 7 ⁷/₈ in. x 9 ¹³/₁₆ in.)

Mass (approx.): 2.0 kg (4.5 lbs)

Supplied accessories

See page 6.

Design and specifications are subject to change without notice.

Authorized Service Centers

QUALITY **JVC**[®] SERVICE
HOW TO LOCATE YOUR JVC SERVICE CENTER
TOLL FREE: 1 (800) 537-5722
<http://www.jvc.com>

Dear Customer,

In order to receive the most satisfaction from your purchase, please read the instruction booklet before operating the unit. In the event that repairs are necessary, please call 1 (800)537-5722 for your nearest authorized servicer or visit our website at **www.JVC.com**

Remember to retain your Bill of Sale for Warranty Service.

Do not service the television yourself

Caution

To prevent electrical shock, do not open the cabinet. There are no user serviceable parts inside. Please refer to qualified service personnel for repairs.

Accessories

To purchase accessories for your JVC product, please call toll free: 1 (800)882-2345 or on the web at **www.JVC.com**



LIMITED WARRANTY

AUDIO-1

JVC COMPANY OF AMERICA warrants this product and all parts thereof, except as set forth below ONLY TO THE ORIGINAL PURCHASER AT RETAIL to be FREE FROM DEFECTIVE MATERIALS AND WORKMANSHIP from the date of original retail purchase for the period as shown below. ("The Warranty Period")

PARTS	1 YR	LABOR	1 YR
-------	-------------	-------	-------------

THIS LIMITED WARRANTY IS VALID ONLY IN THE FIFTY (50) UNITED STATES, THE DISTRICT OF COLUMBIA AND IN COMMONWEALTH OF PUERTO RICO.

WHAT WE WILL DO:

If this product is found to be defective, JVC will repair or replace defective parts at no charge to the original owner. Such repair and replacement services shall be rendered by JVC during normal business hours at JVC authorized service centers. Parts used for replacement are warranted only for the remainder of the Warranty Period. All products and parts thereof may be brought to a JVC authorized service center on a carry-in basis except for Television sets having a screen size 25 inches and above which are covered on an in-home basis.

WHAT YOU MUST DO FOR WARRANTY SERVICE:

Return your product to a JVC authorized service center with a copy of your bill of sale. For your nearest JVC authorized service center, please call toll free: (800) 537-5722.

If service is not available locally, box the product carefully, preferably in the original carton, and ship, insured, with a copy of your bill of sale plus a letter of explanation of the problem to the nearest JVC Factory Service Center, the name and location of which will be given to you by the toll-free number.

If you have any questions concerning your JVC Product, please contact our Customer Relations Department.

WHAT IS NOT COVERED:

This limited warranty provided by JVC does not cover:

1. Products which have been subject to abuse, accident, alteration, modification, tampering, negligence, misuse, faulty installation, lack of reasonable care, or if repaired or serviced by anyone other than a service facility authorized by JVC to render such service, or if affixed to any attachment not provided with the products, or if the model number or serial number has been altered, tampered with, defaced or removed;
2. Initial installation and installation and removal for repair;
3. Operational adjustments covered in the Owner's Manual, normal maintenance, video and audio head cleaning;
4. Damage that occurs in shipment, due to act of God, and cosmetic damage;
5. Signal reception problems and failures due to line power surge;
6. Video Pick-up Tubes/CCD Image Sensor, Cartridge, Stylus (Needle) are covered for 90 days from the date of purchase;
7. Accessories
8. Batteries (except that Rechargeable Batteries are covered for 90 days from the date of purchase);

There are no express warranties except as listed above.

THE DURATION OF ANY IMPLIED WARRANTIES, INCLUDING THE IMPLIED WARRANTY OF MERCHANTABILITY, IS LIMITED TO THE DURATION OF THE EXPRESS WARRANTY HEREIN.

JVC SHALL NOT BE LIABLE FOR THE LOSS OF USE OF THE PRODUCT, INCONVENIENCE, LOSS OR ANY OTHER DAMAGES, WHETHER DIRECT, INCIDENTAL OR CONSEQUENTIAL (INCLUDING, WITHOUT LIMITATION, DAMAGE TO TAPES, RECORDS OR DISCS) RESULTING FROM THE USE OF THIS PRODUCT, OR ARISING OUT OF ANY BREACH OF THIS WARRANTY. ALL EXPRESS AND IMPLIED WARRANTIES, INCLUDING THE WARRANTIES OF MERCHANTABILITY AND FITNESS FOR PARTICULAR PURPOSE, ARE LIMITED TO THE WARRANTY PERIOD SET FORTH ABOVE.

Some states do not allow the exclusion of incidental or consequential damages or limitations on how long an implied warranty lasts, so these limitations or exclusions may not apply to you. This warranty gives you specific legal rights and you may also have other rights which vary from state to state.

JVC COMPANY OF AMERICA 1700 Valley Road
 DIVISION OF JVC AMERICAS CORP. Wayne, NJ 07470

REFURBISHED PRODUCTS CARRY A SEPARATE WARRANTY, THIS WARRANTY DOES NOT APPLY. FOR DETAILS OF REFURBISHED PRODUCT WARRANTY, PLEASE REFER TO THE REFURBISHED PRODUCT WARRANTY INFORMATION PACKAGED WITH EACH REFURBISHED PRODUCT.

For customer use:

Enter below the Model No. which is located either on the rear, bottom or side of the cabinet. Retain this information for future reference.

Model No. : _____

Serial No. : _____

Purchase data : _____

Name of dealer : _____



JVC
VICTOR COMPANY OF JAPAN, LIMITED